工程與生活：

Automotive Electronic Systems

電子系 黃其泮

Outlines

- Developing Trends of Automotive Electronic Systems
 - Emerging In-Vehicle Networks
-

Developing Trends of Automotive Electronic Systems

Automotive Electronic Systems Today

VW Phaeton:

- 11.136 electrical parts in total

communication:

- **61 ECUs in total**
- external diagnosis for 31 ECUs via serial communication
- optical bus for high bandwidth Infotainment-data
- **sub-networks** based on proprietary serial bus
- **35 ECUs** connected by **3 CAN-busses**

sharing

- appr. 2500 signals
- in 250 CAN messages



Expanding Automotive Electronic Systems

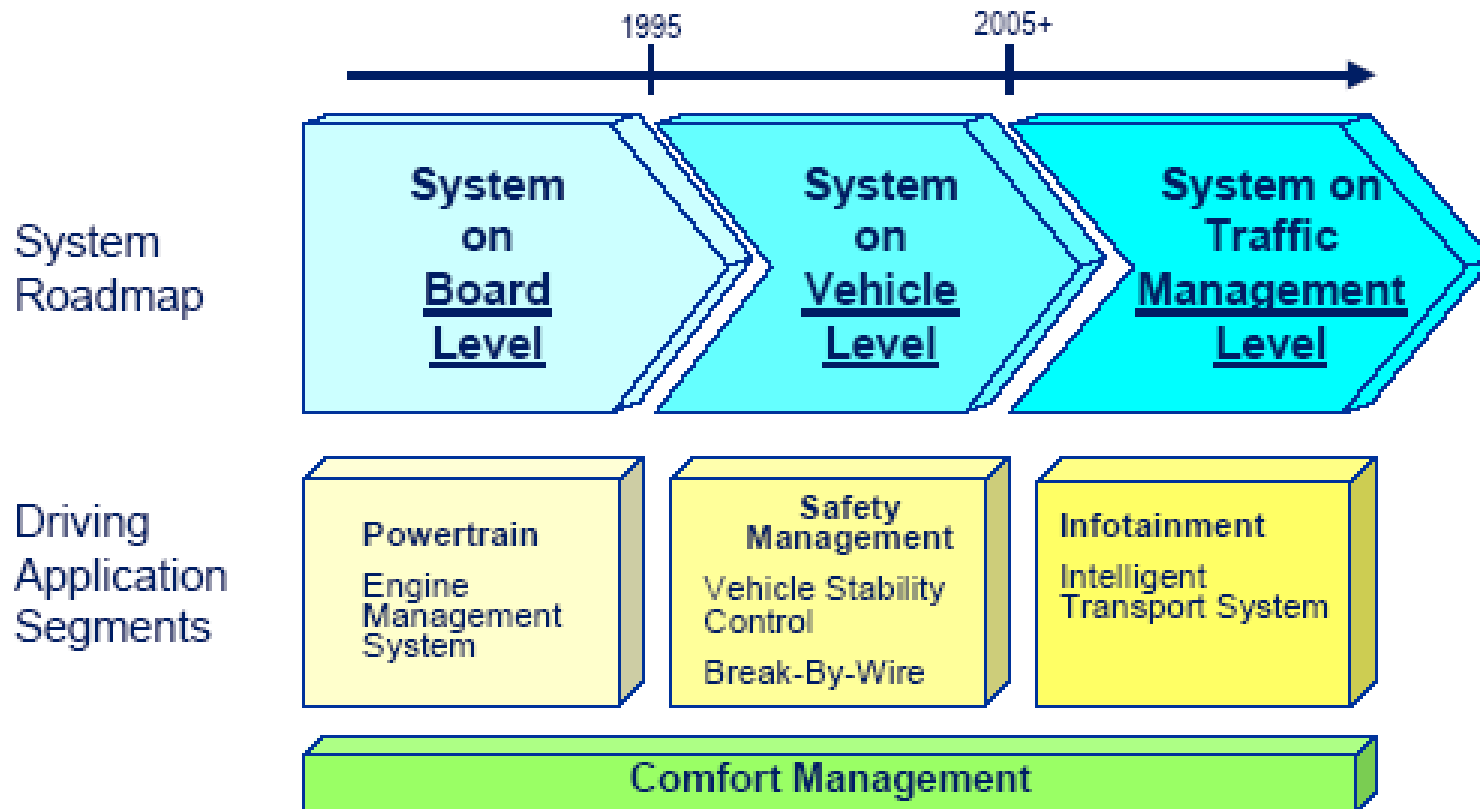

Expanding Automotive Electronic Systems

- The mature subsystems of automotive electronic systems
 - Powertrain/Body control—EMS, ABS, ...
 - Themes of current stage
 - X-by-wire—an ongoing revolution in vehicle electronics architecture
 - Themes of next stage
 - Infotainment= Entertainment + Communication + Information
-

Expanding Automotive Electronic Systems

- Analysts estimate that more than 80 percent of all automotive innovation now stems from electronics
 - To embed the electronic systems and silicon components—such as transistors, microprocessors, and diodes—into motor vehicles is the developing trend of automotive electronic systems
-

System Structure of ECU

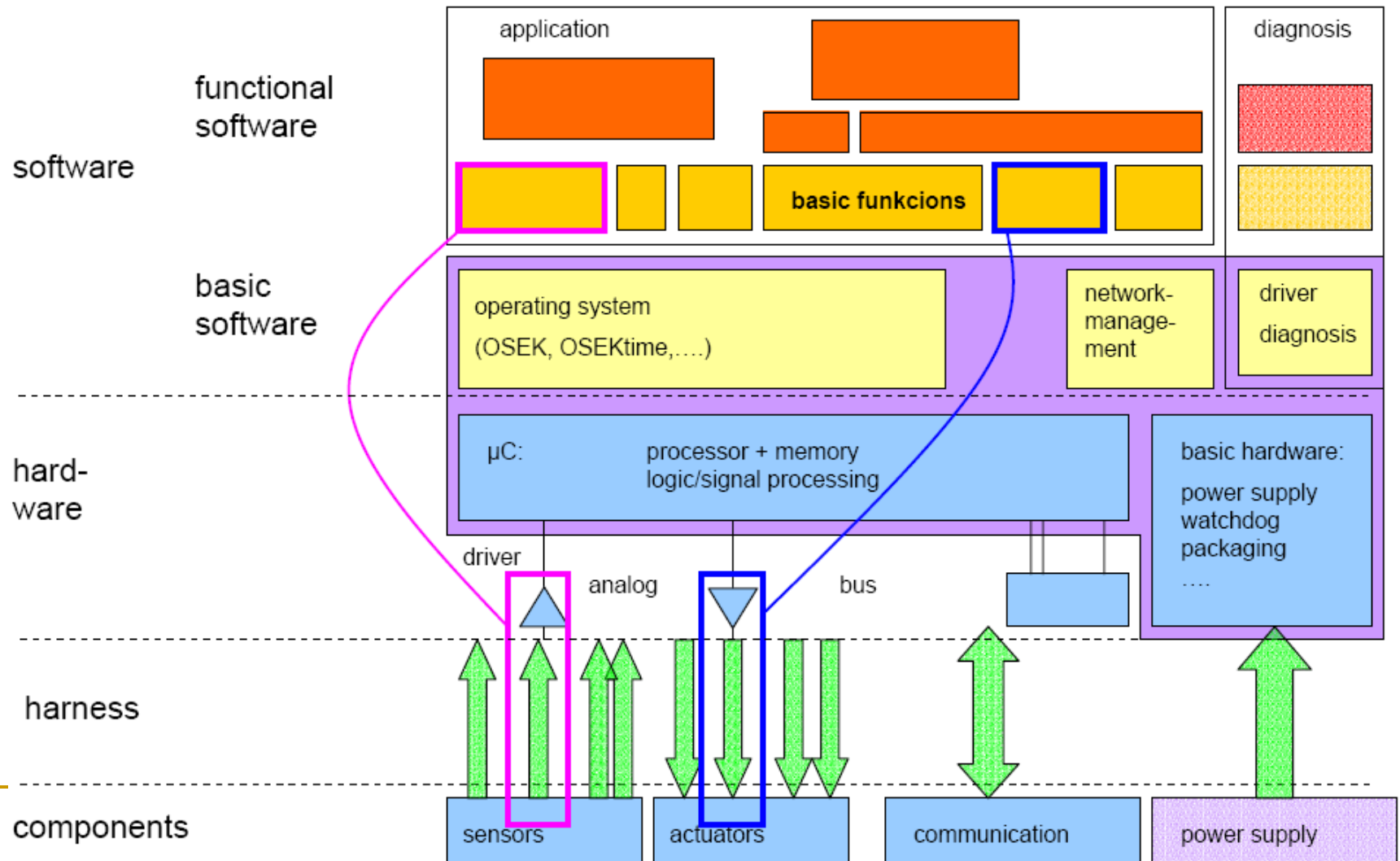

System Structure of ECU

■ Example

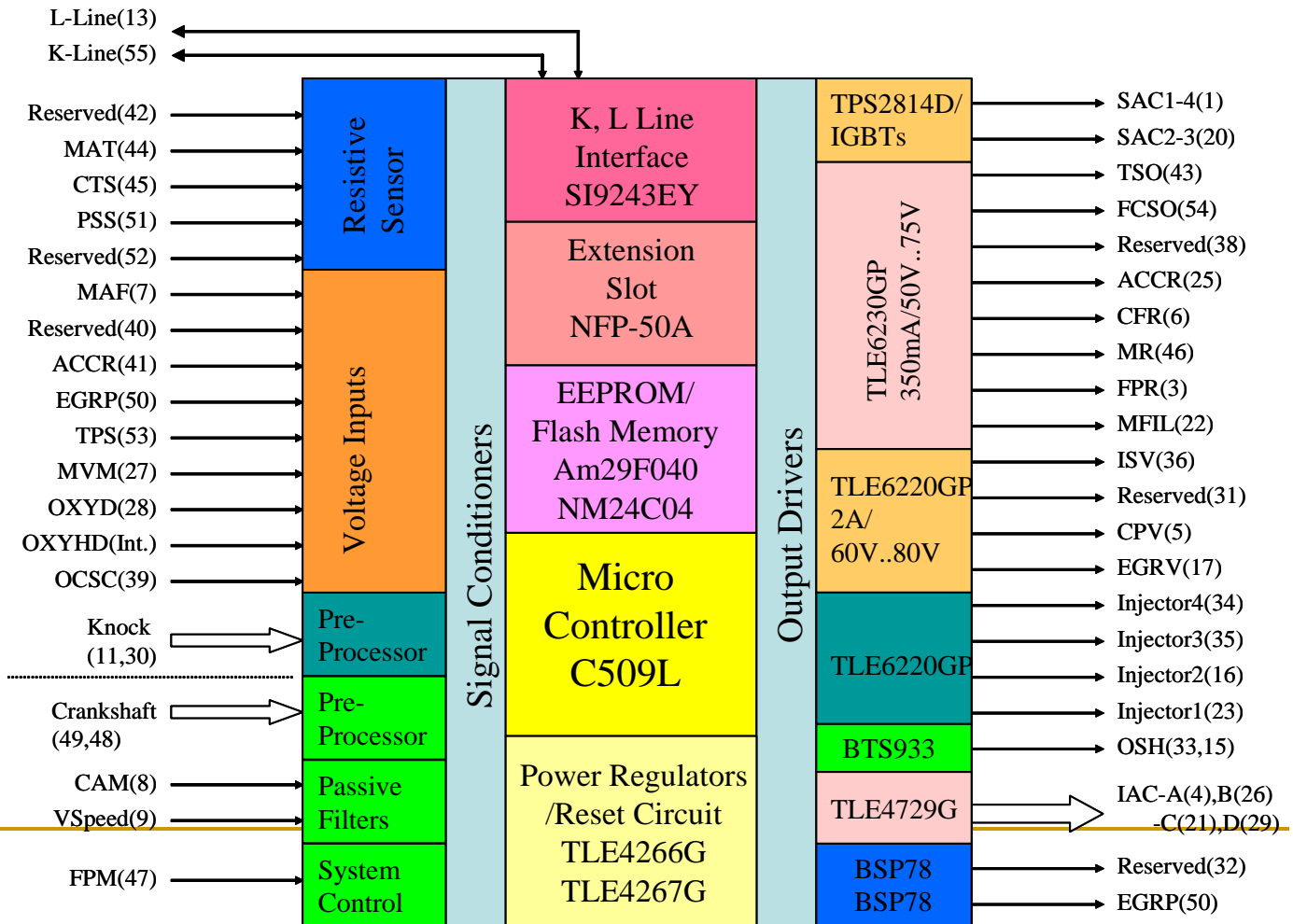

Developing Trends of Automotive Electronic Systems

- System requirements
 - Standardization of functional interfaces
 - Share and reuse the existing components
 - Comprehensive safety
 - A high degree of comfort
 - Low energy consumption, and
 - Minimal pollutant emission
-

Developing Trends of Automotive Electronic Systems

- Issues of system development
 - Integrate and reuse the software and hardware cores from multiple vendors
 - Innovative functionality realized through interaction of formerly autonomous units (reconfigurable distributed systems/mechatronics)
 - Scalability to different vehicle and platform variants
-

Developing Trends of Automotive Electronic Systems

- ❑ Design Toolkits
 - ❑ Digital Transmission Capability
 - ❑ Transferability of functions throughout network
 - ❑ Maintainability throughout the whole “Product Life Cycle“
-

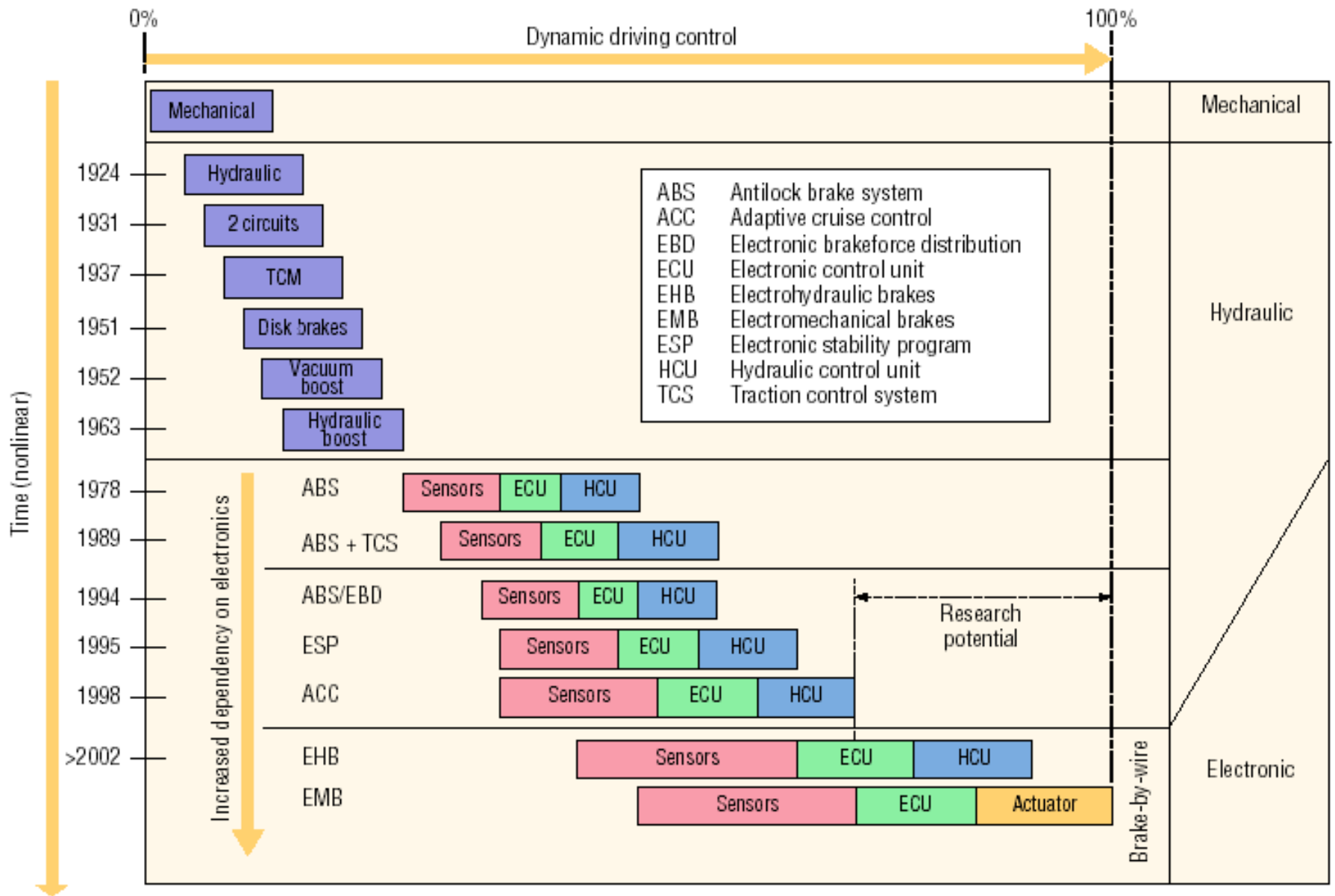

referring to: G. Leen and D. Heffernan, "Expanding Automotive Electronic Systems"

Developing Trends of Automotive Electronic Systems

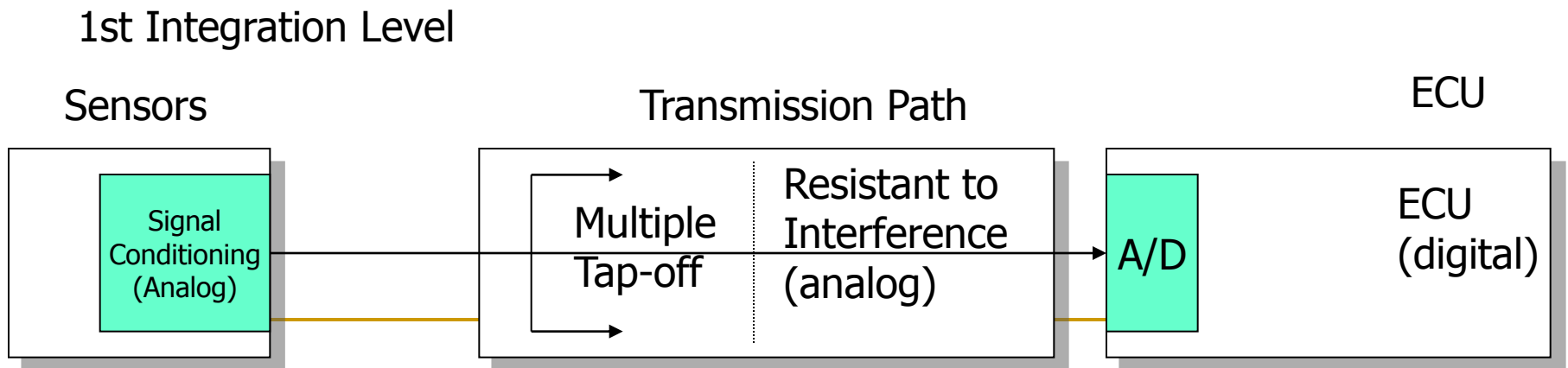
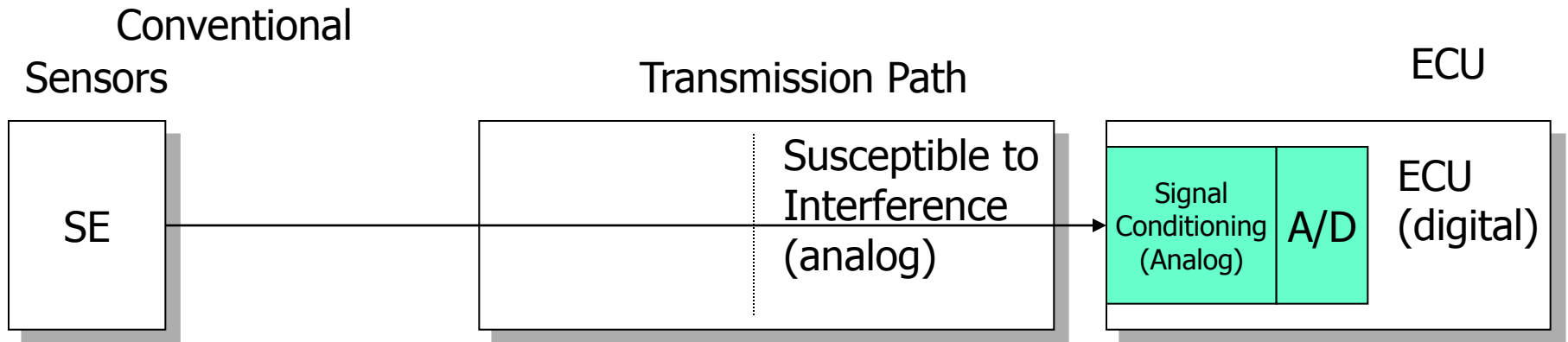

Developing Trends of Automotive Electronic Systems

2nd Integration Level

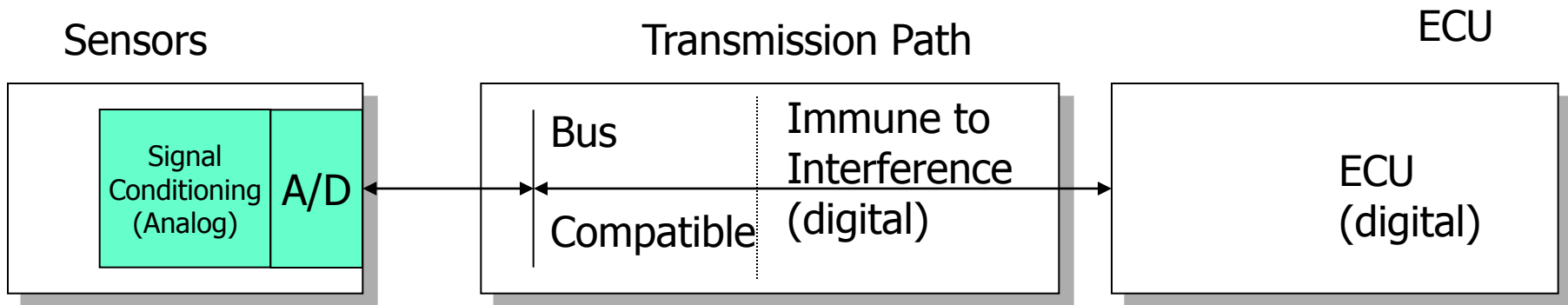

3rd Integration Level

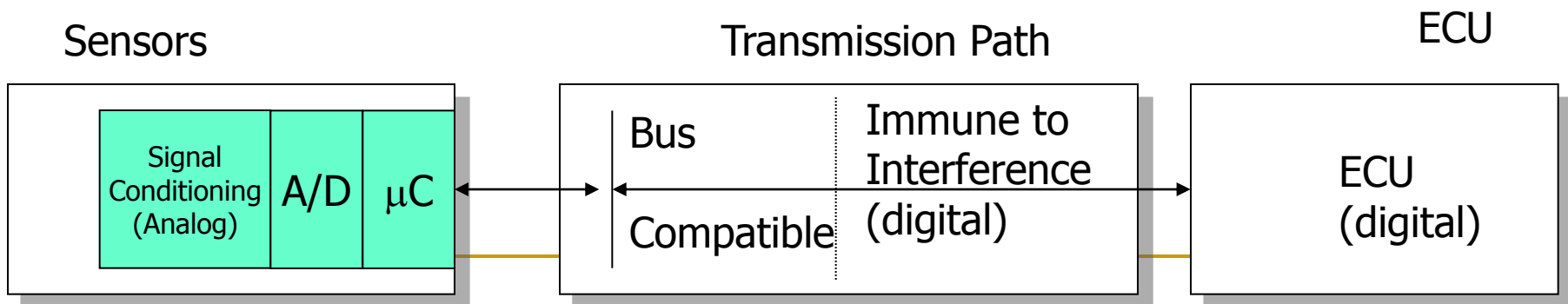

Developing Trends of Automotive Electronic Systems

- Mechatronics



Developing Trends of Automotive Electronic Systems

- Issues of hardware development
 - Exhibit immunity from radio emissions
 - Reducing the hardware cost and size
 - With high computing power
 - Transient faults well be tolerated
 - Embedded network
 - A variety of sensor/actuator interface capabilities
-

Safety and safeguarding

Ranging radar (ACC, precrash)

Tilt sensor (headlamp aiming)

High-pressure sensor (ESP)

Torque sensor (power steering)

Steering-wheel-angle sensor (ESP)

Acceleration sensor (airbag)

Seat-occupation sensor (airbag)

Yaw-rate sensor (ESP)

Acceleration sensor (ABS and anti-theft systems)

Yaw-rate sensor (roll-over sensing)

Wheel-speed sensor (ABS)

Drivetrain

Pressure sensor (transmission-shift control, Motronic)

Boost-pressure sensor (Diesel Control (EDC), Motronic)

Air-mass meter (Motronic)

Knock sensor (electronic Diesel Control (EDC), Motronic)

Atmospheric-pressure sensor (Motronic)

High-pressure sensor (direct-injection, Common Rail)

Lambda oxygen sensor (Motronic)

Rotational-speed sensor (transmission-shift control, Motronic)

Tank-pressure sensor (On-Board Diagnostics (OBD))

Accelerator-pedal sensor (Control (ETC), electronic Throttle (Motronic))

Angle-of-rotation and position sensor (Electronic Throttle (EHB))

Yaw-rate sensor (navigation)

Air-quality sensor (air-conditioning)

Humidity/Temperature sensor (central locking system)

Pressure sensor (windshield-wiper control)

Rain sensor (back-up monitoring)

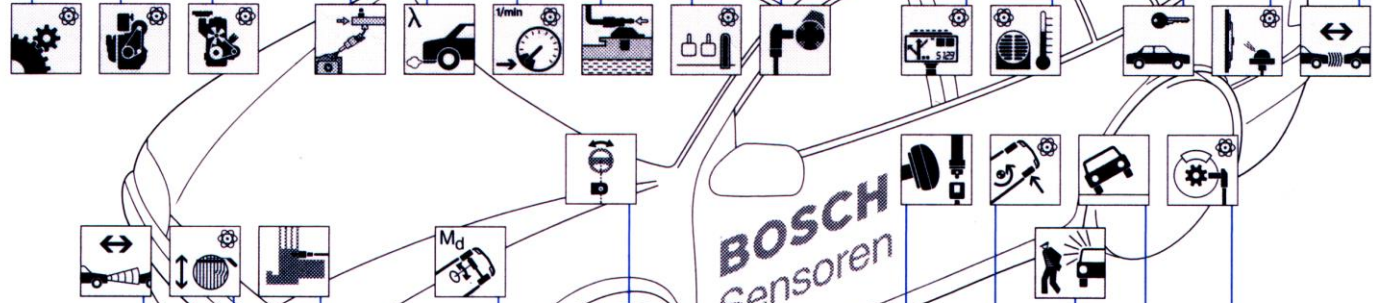

BOSCH
Sensoren

Developing Trends of Automotive Electronic Systems

- Issues of software development
 - Real-time operating system
 - Software component paradigm
 - Software updates and upgrades over vehicle lifetime
 - Minimizing the cost and execution time of software components
 - Uniform data format and seamless software component interface
-

Developing Trends of Automotive Electronic Systems

- Rise of importance of software in the Car

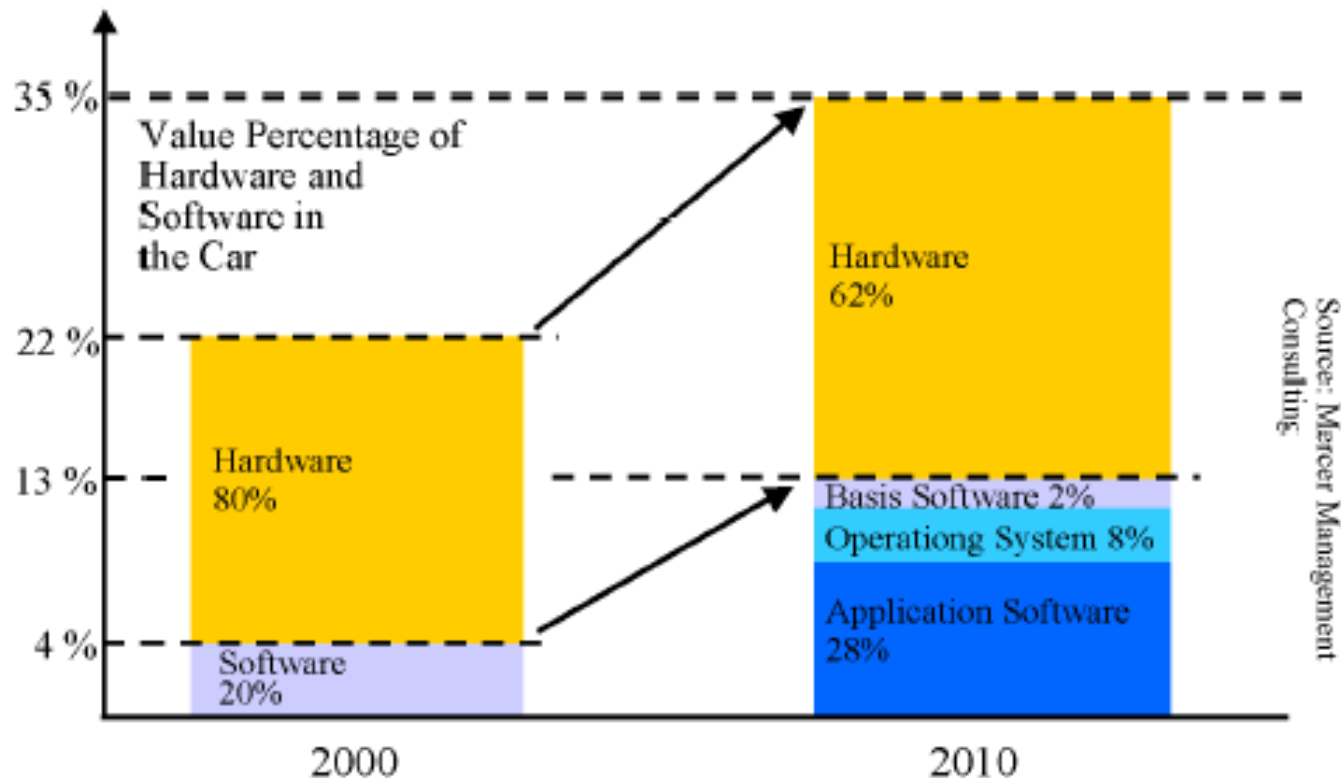

Developing Trends of Automotive Electronic Systems

- Example of software cores (components)

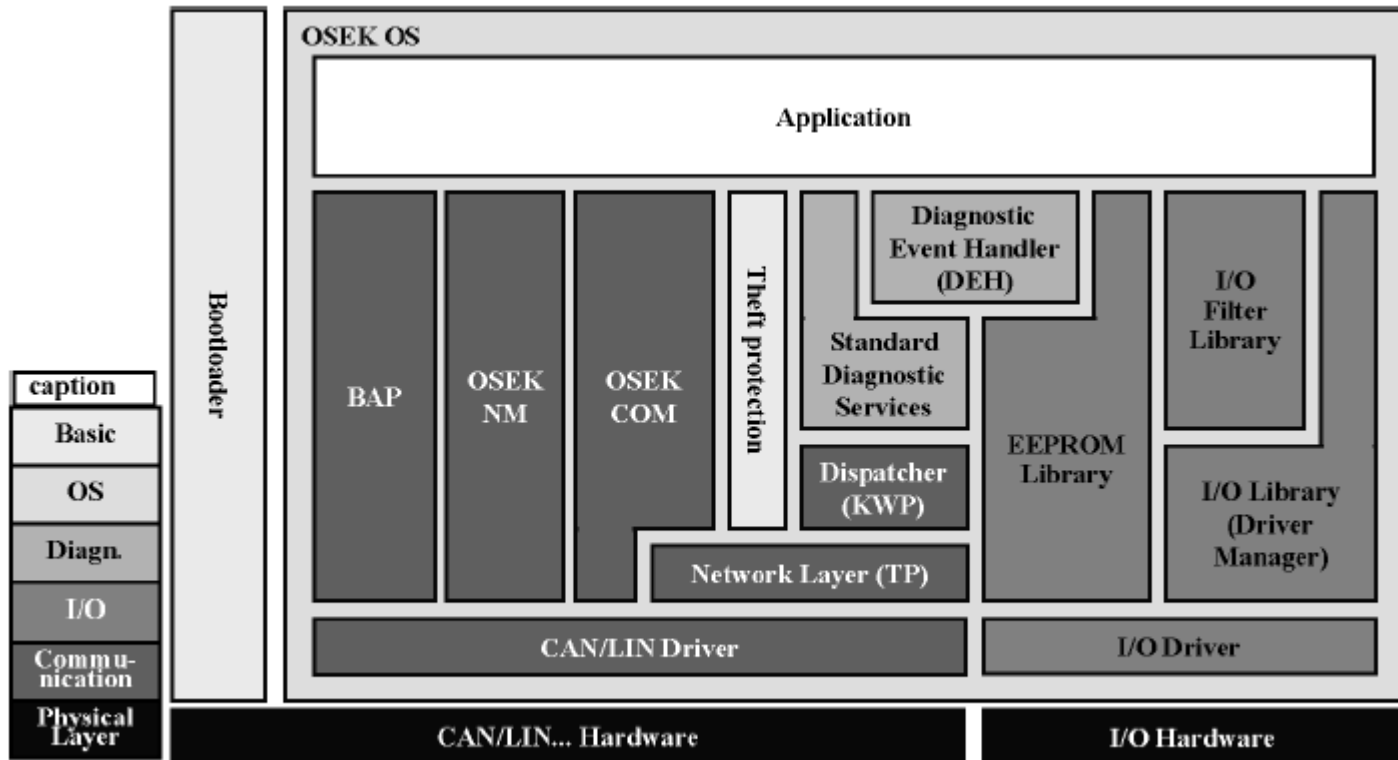

Developing Trends of Automotive Electronic Systems

- **Standardized systems (Open systems)**
 - Management of automotive electronic systems complexity associated with growth in functional scope
 - Flexibility for product modification, upgrade and update
 - Scalability of solutions within and across product lines
 - Improved quality and reliability of automotive electronic systems
-

Developing Trends of Automotive Electronic Systems

■ OSEK/VDX

- OSEK/VDX is a joint project of the automotive industry (1993)
 - It aims at an industry standard for an open-ended architecture for distributed control units in vehicles
-

Developing Trends of Automotive Electronic Systems

- ❑ The term OSEK means "Offene Systeme und deren Schnittstellen für die Elektronik im Kraftfahrzeug" (Open systems and the corresponding interfaces for automotive electronics).
 - ❑ The term VDX means „Vehicle Distributed eXecutive“
-

Developing Trends of Automotive Electronic Systems

- The OSEK/VDX specifies
 - Real-time operating system
 - Software interfaces and functions for communication, and
 - Software for network management
-

Developing Trends of Automotive Electronic Systems

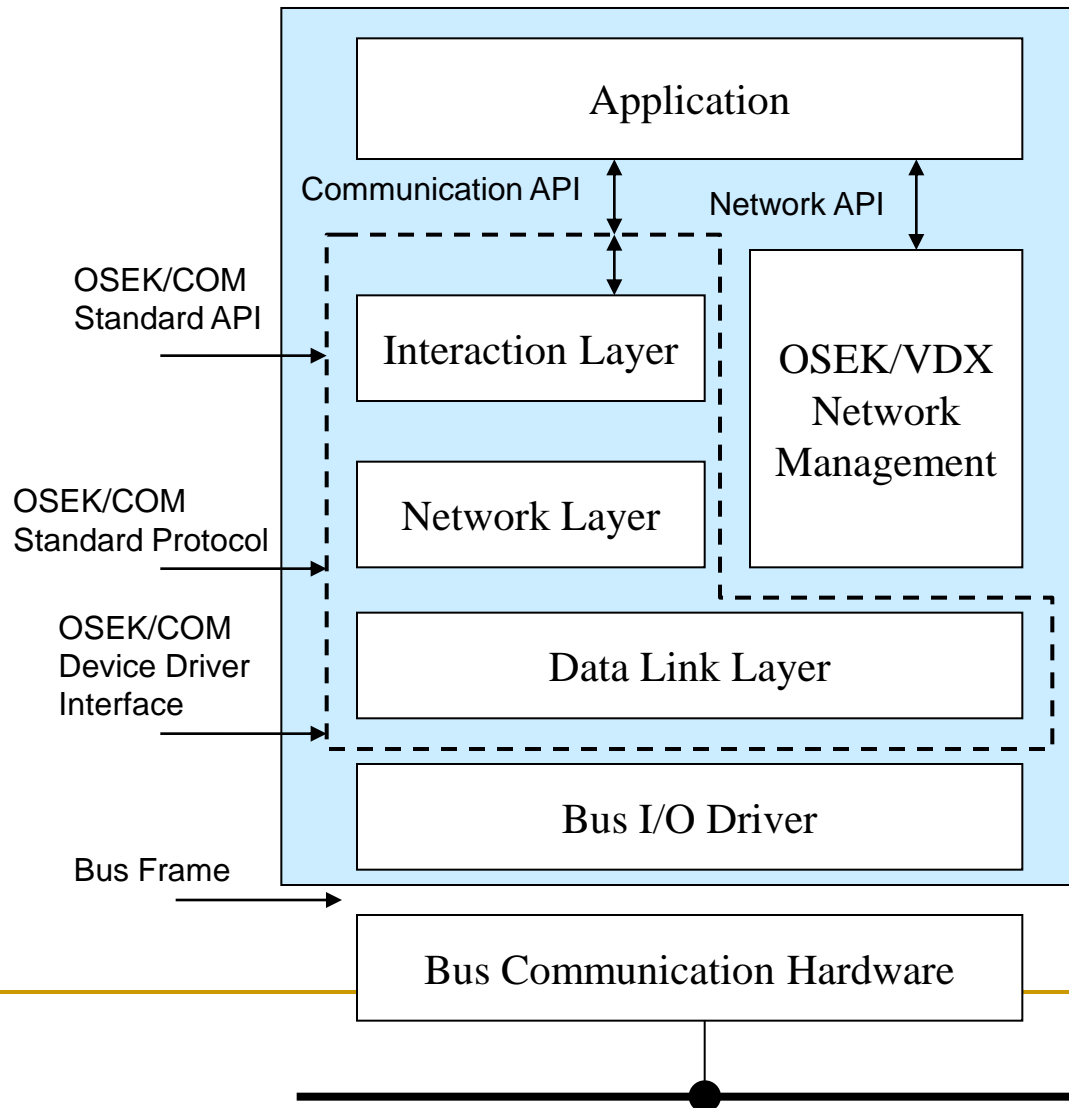

Developing Trends of Automotive Electronic Systems

- Automotive Open System Architecture (AUTOSAR):
 - Standardization of different APIs to separate the AUTOSAR software layers
 - Encapsulation of functional software-components
 - Definition of the data types of the software-components
-

Developing Trends of Automotive Electronic Systems

- Identification of basic software modules of the software infrastructure and standardize their interfaces



Developing Trends of Automotive Electronic Systems

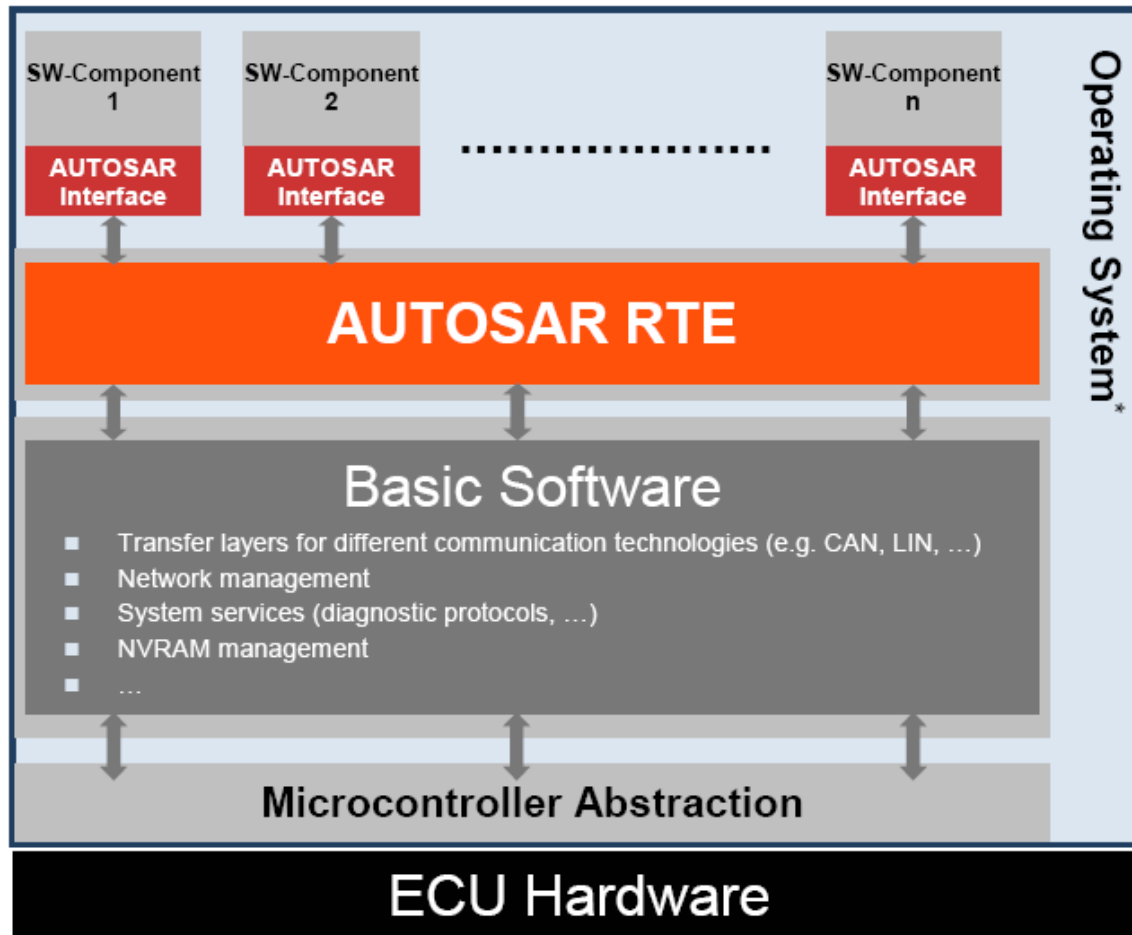

Developing Trends of Automotive Electronic Systems

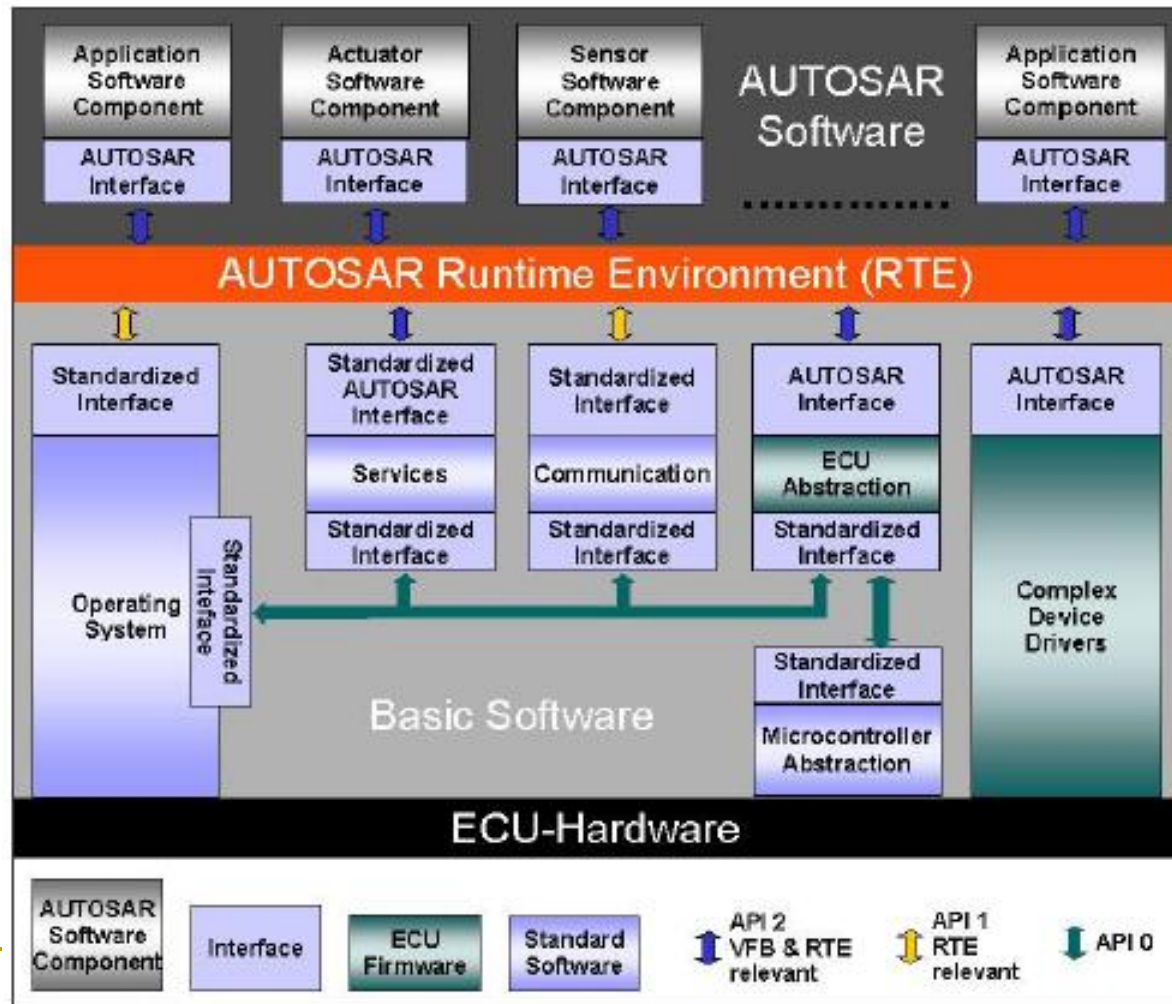

Developing Trends of Automotive Electronic Systems

- One ECU example

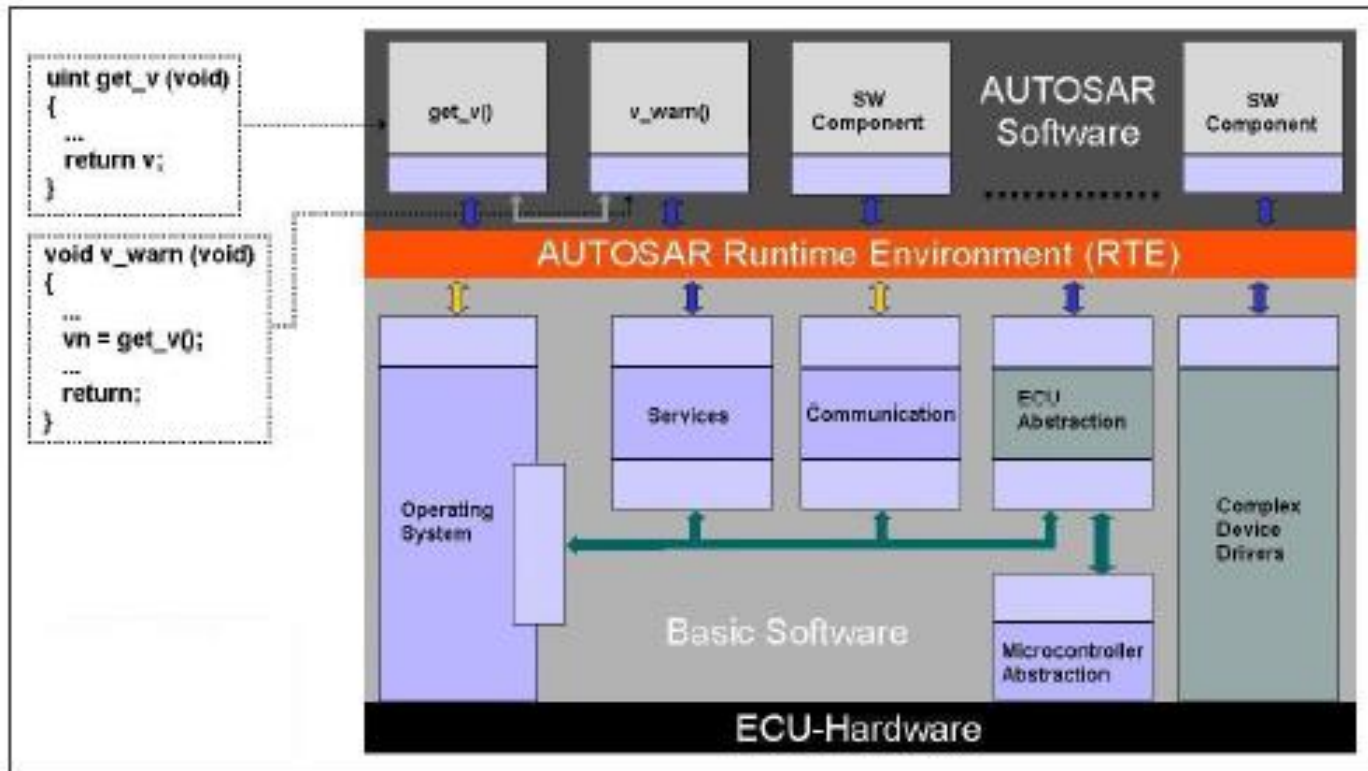

Developing Trends of Automotive Electronic Systems

- Two ECUs example



Thank you for your attention!

Discussion
