



工程與生活

科技新生活與微光機電技術

國立彰化師範大學

機電工程學系 王可文 編

Prepared by Kerwin Wang

Department of Mechatronics Engineering



- **LIGHT & HUMAN EYES**



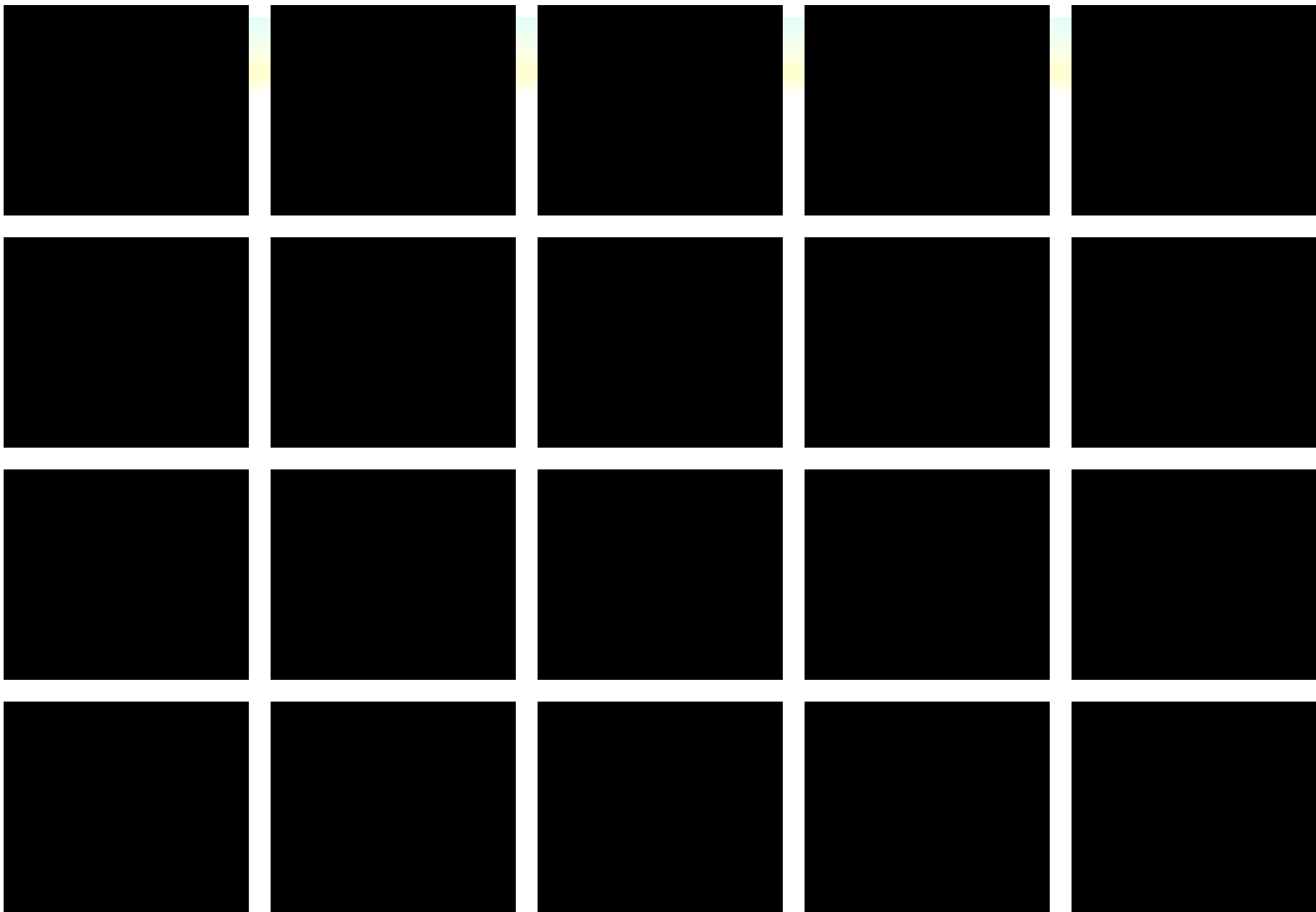

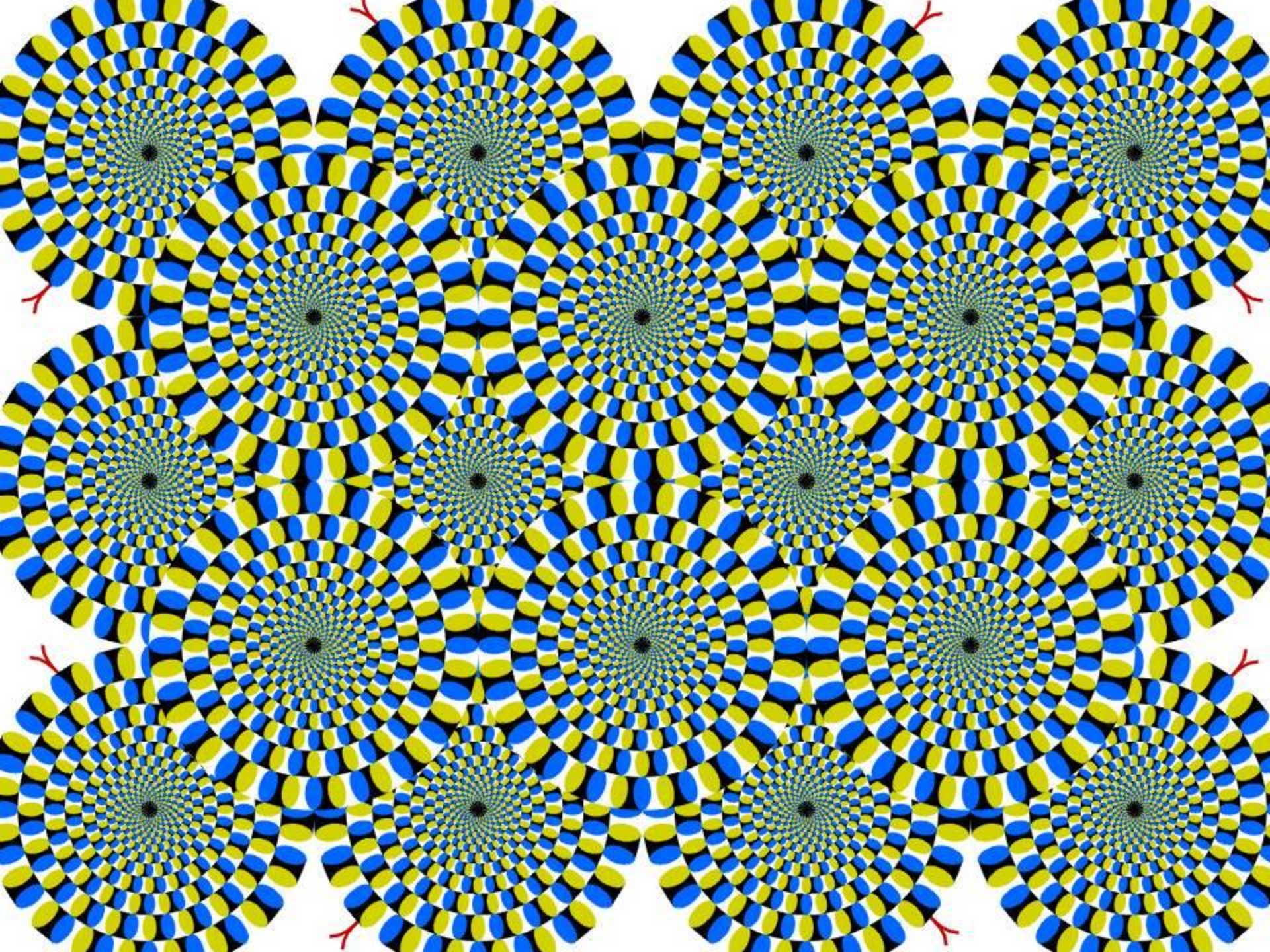

From pixels to eyes

- Transmissive optics

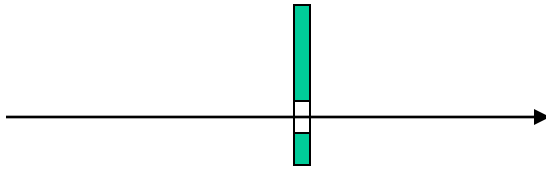

- Reflective optics

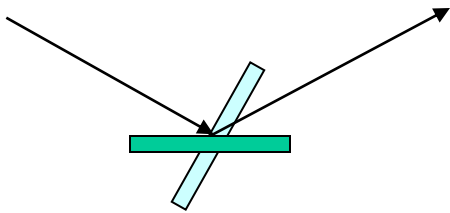

- Self-illuminative optics

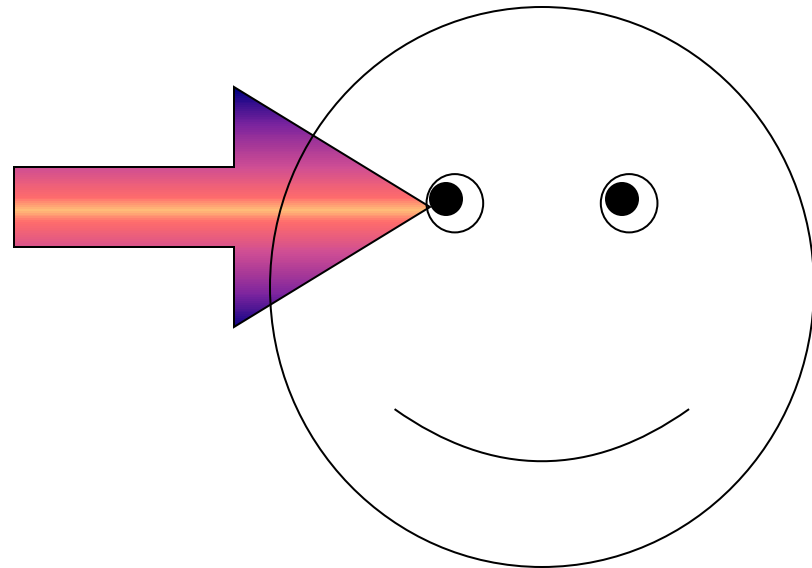
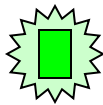

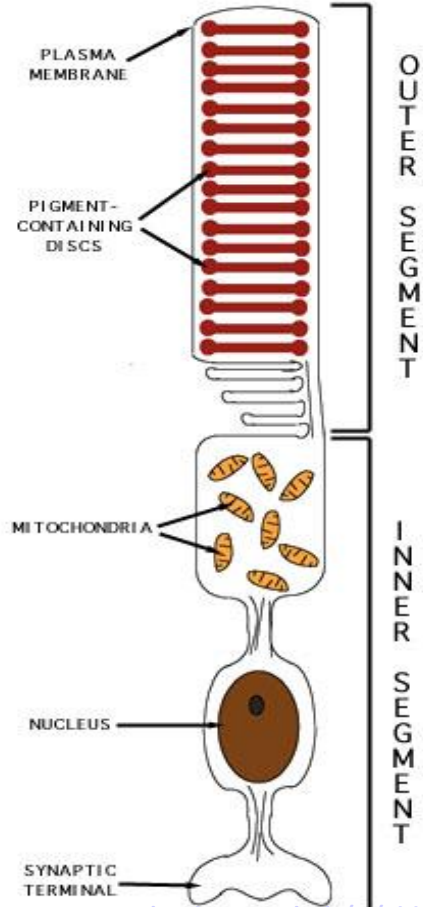
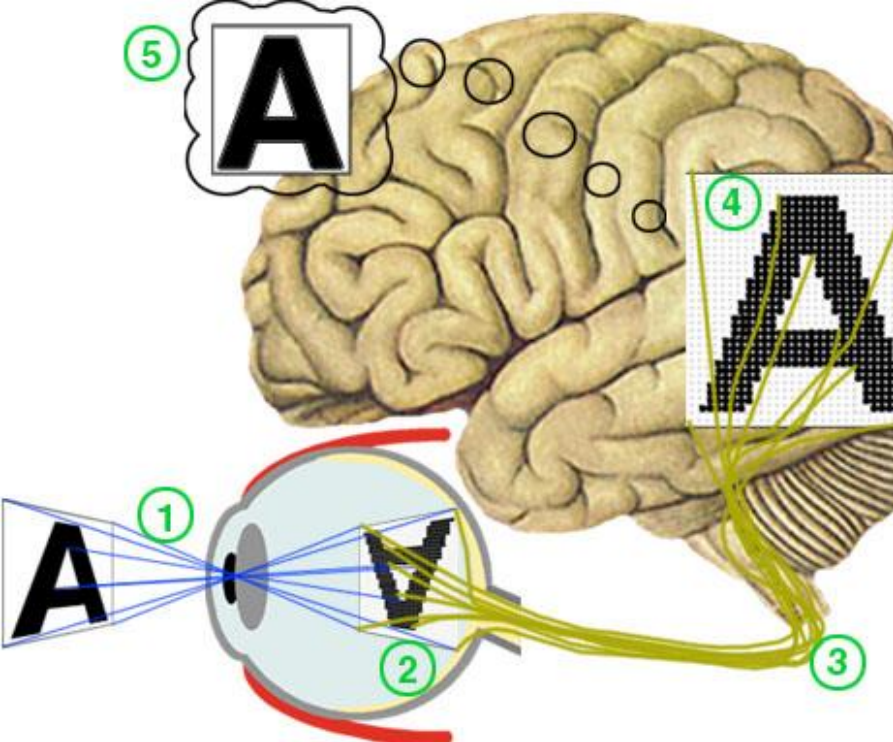

OUTER SEGMENT

INNER SEGMENT

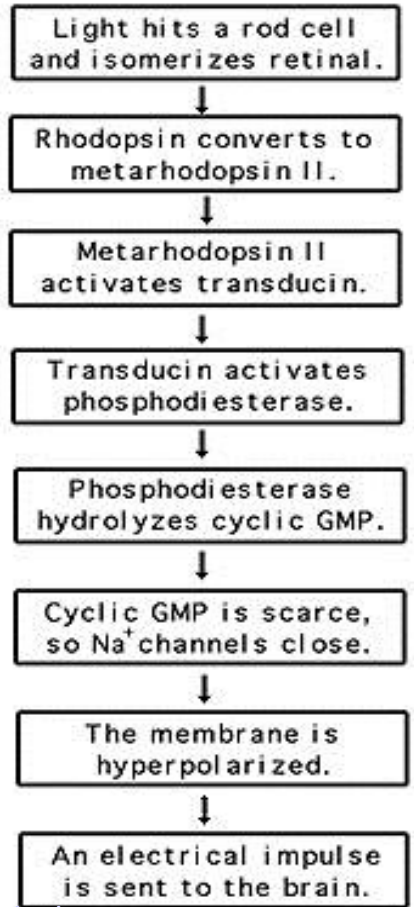

www.chemistry.wustl.edu/~Vision/Vision.html

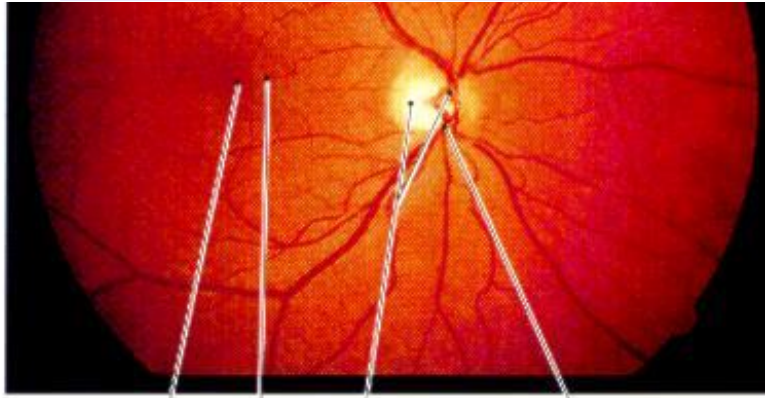
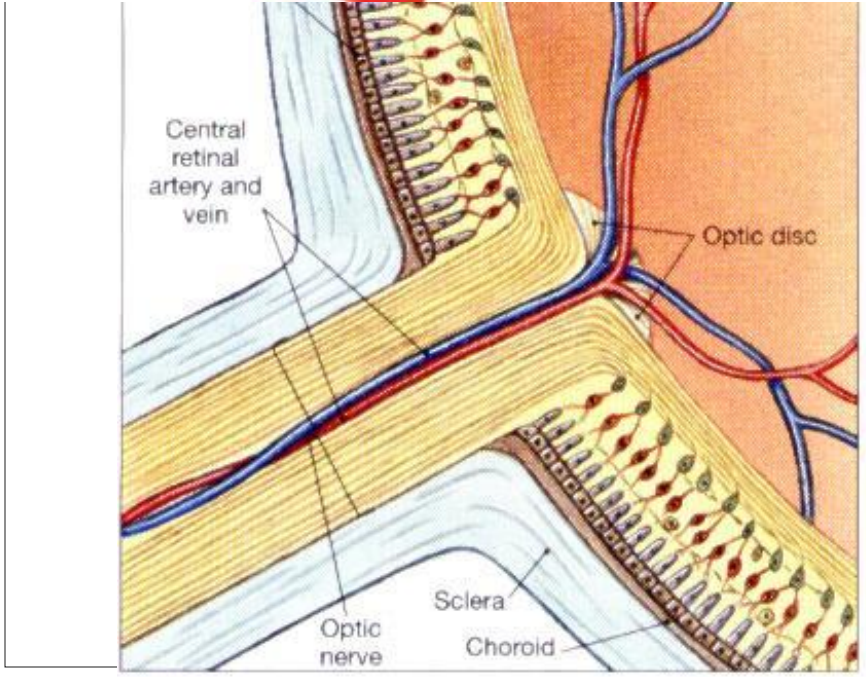

Fovea Macula lutea Optic disc (blind spot) Central retinal artery and vein emerging from center of optic disc

THE SENSORY PHYSIOLOGY

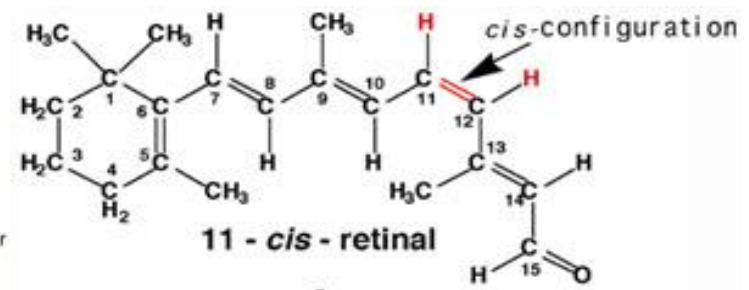
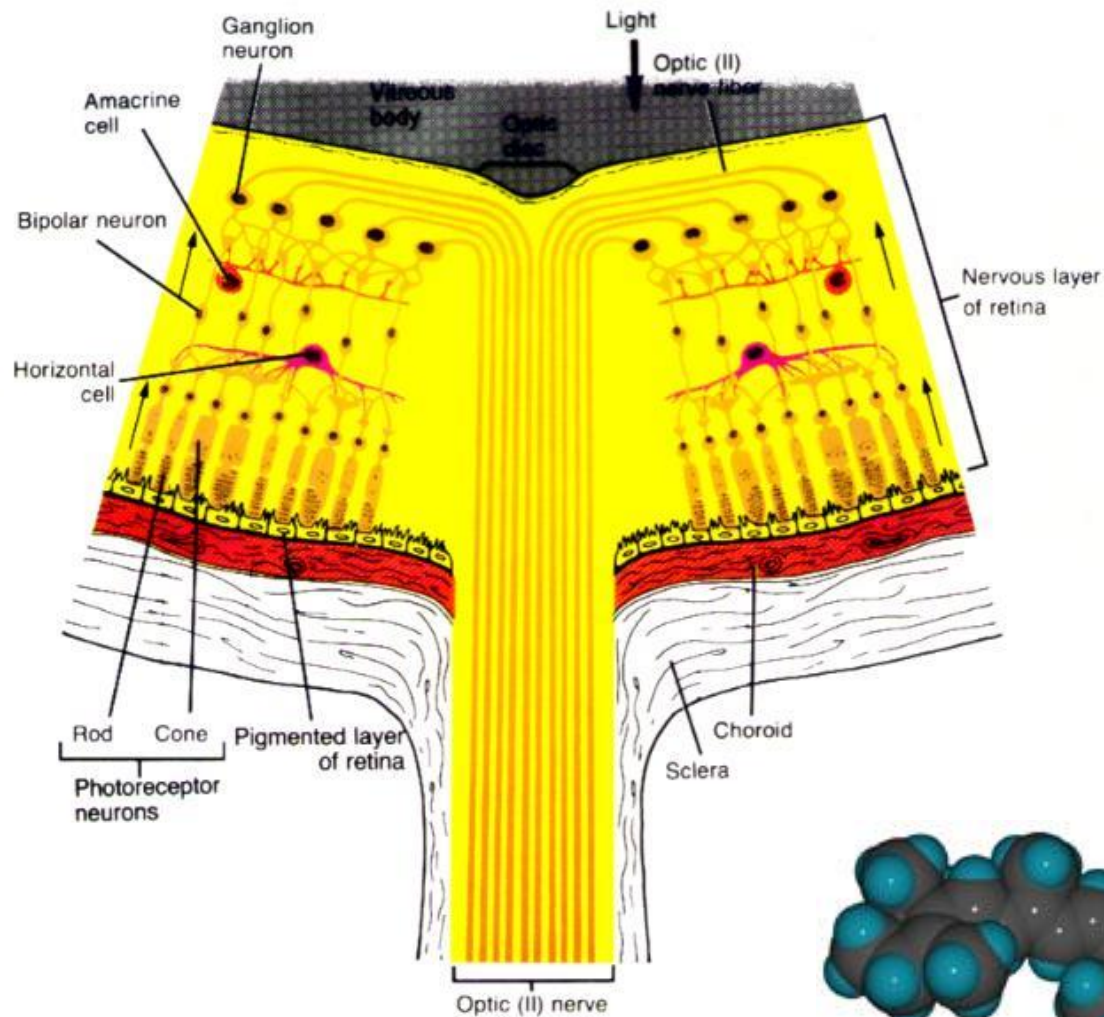

Visible light

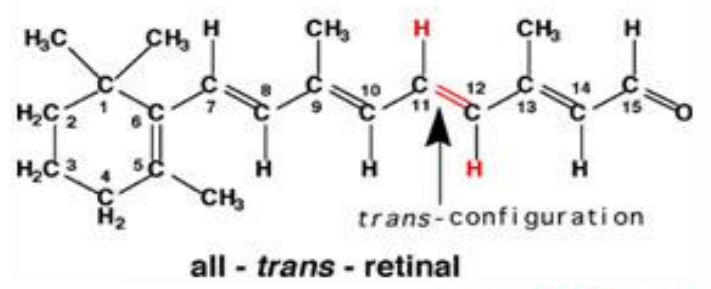

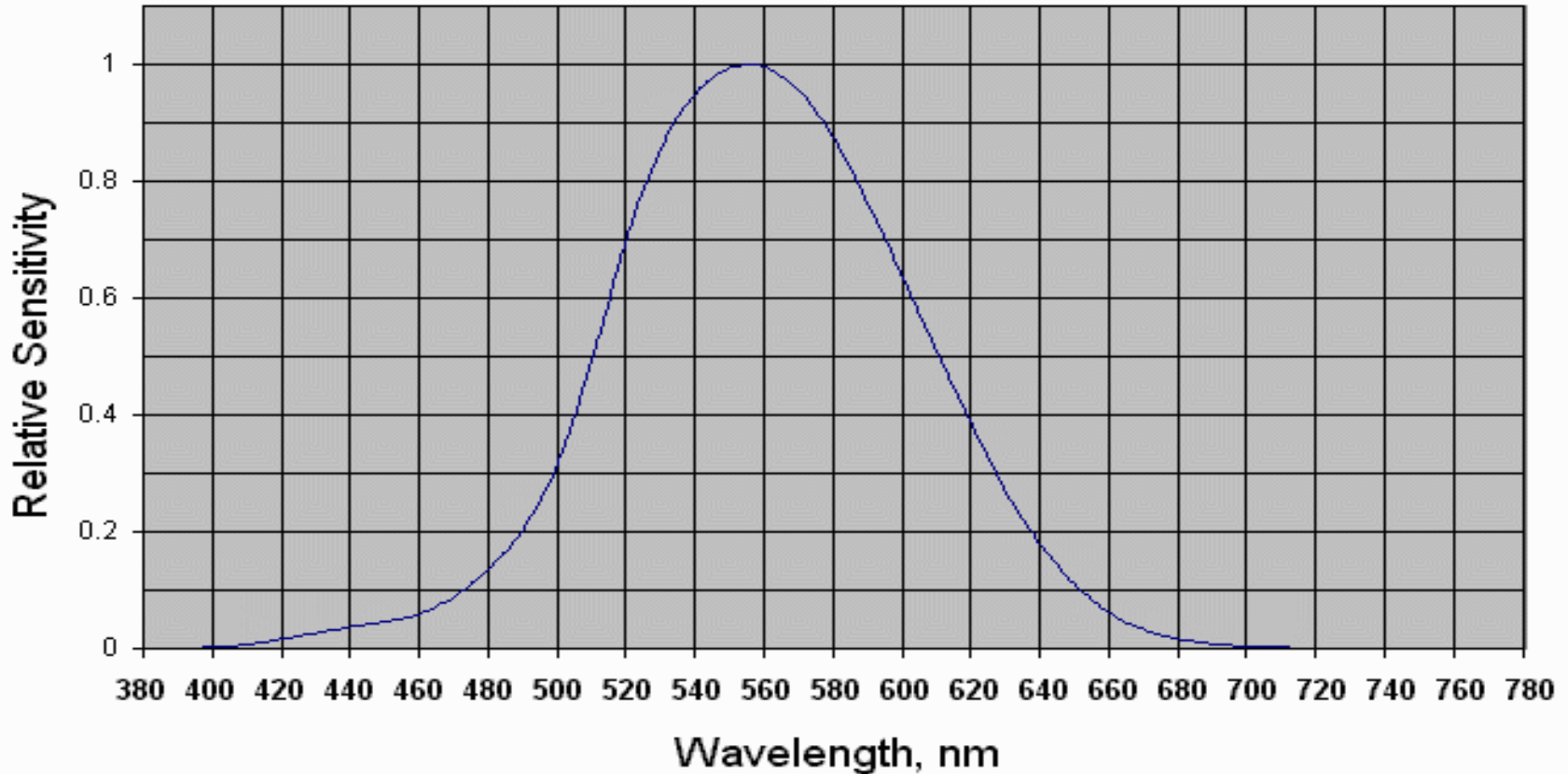
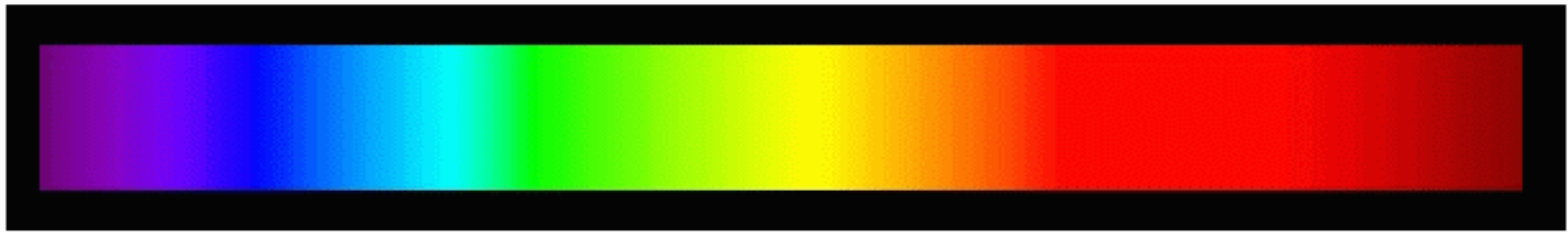

Response of Human Eye Versus Wavelength
(Data from the 1988 C.I.E. Photopic Luminous Efficiency Function)

Biology of the Eyes

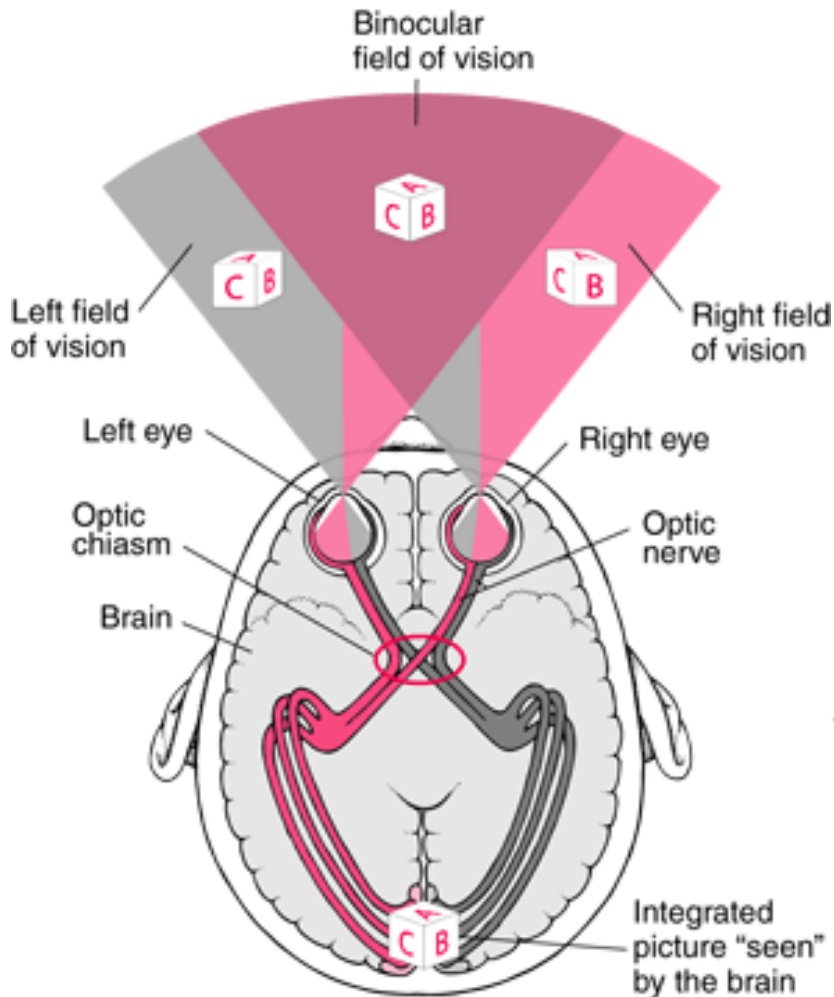

- Nerve signals travel from each eye along the corresponding optic nerve and other nerve fibers to the back of the brain, where vision is sensed and interpreted. The two optic nerves meet at the optic chiasm. There, the optic nerve from each eye divides, and half of the nerve fibers from each side cross to the other side and continue to the back of the brain. Thus, the both side (right & left) of the brain receives information through both optic nerves. The middle of these fields of vision overlaps. It is seen by both eyes (called binocular vision).
- An object is seen from slightly different angles by each eye so the information the brain receives from each eye is different, although it overlaps. The brain integrates the information to produce a complete picture.

Why We Can See the Stereo TV?

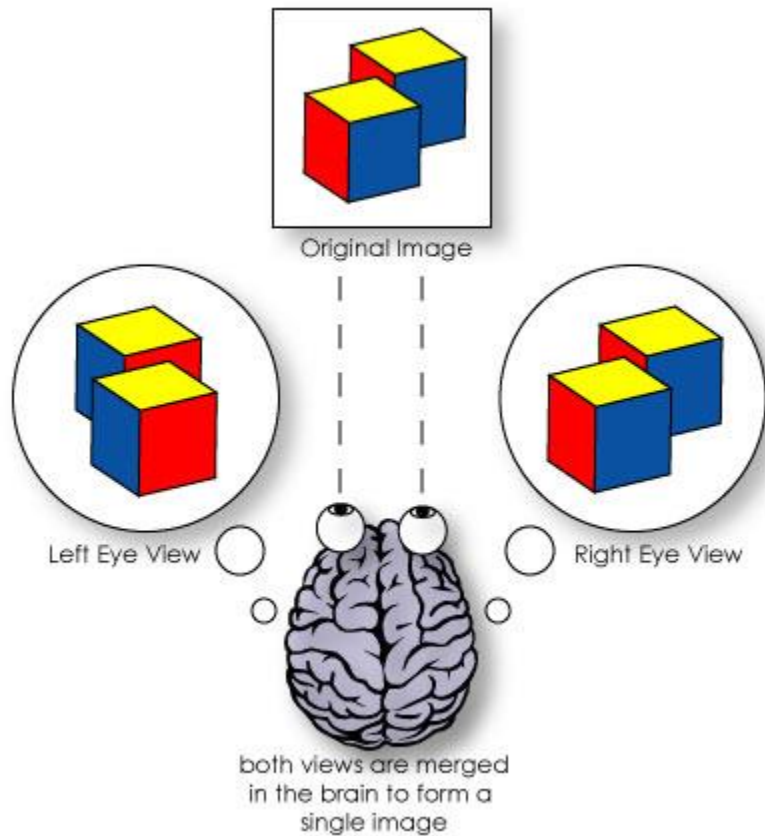

Coding and Signal Processing Technology



Disparity in stereo pair (3D) pictures

Photoconductive cells

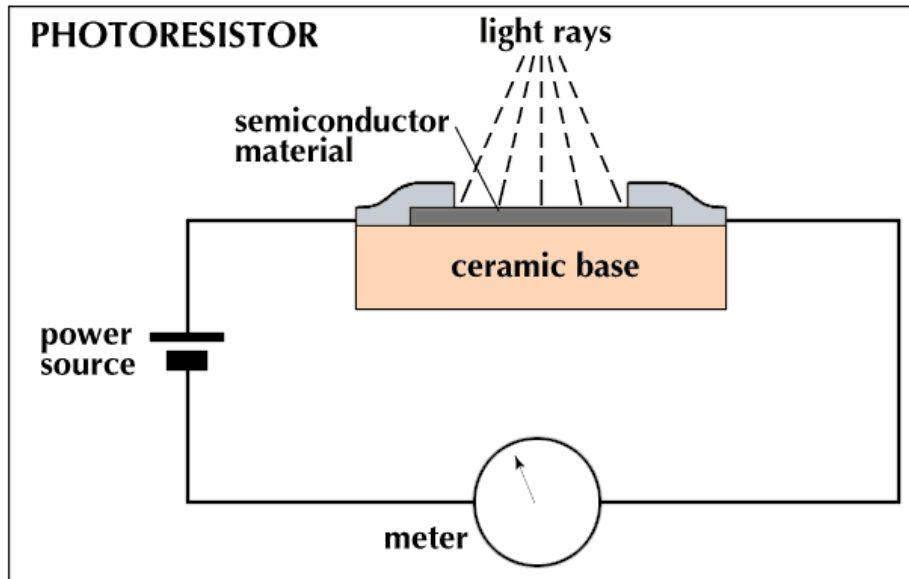

Photoresistors: a photosensitive crystalline materials such as cadmium Sulfide (CdS) or lead sulfide (PbS) is deposited on a ceramic substance.

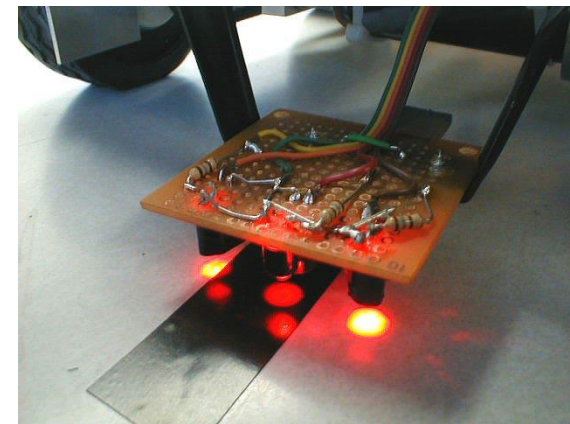
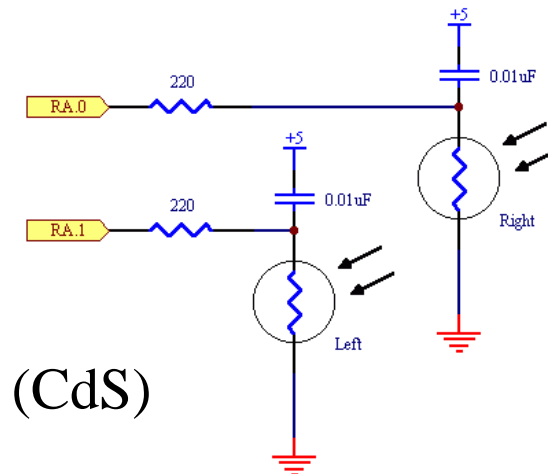
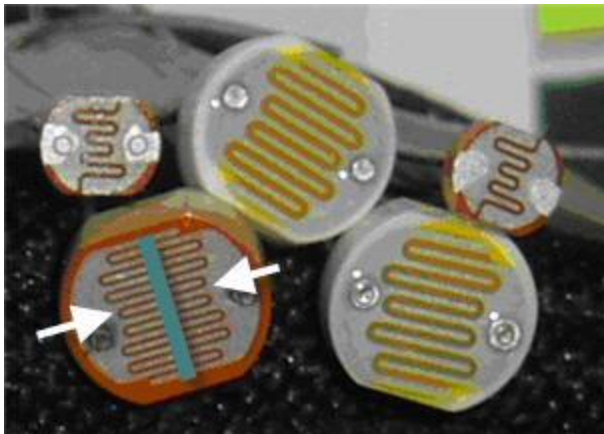

Dual Character of Light

Light as Particles and Waves

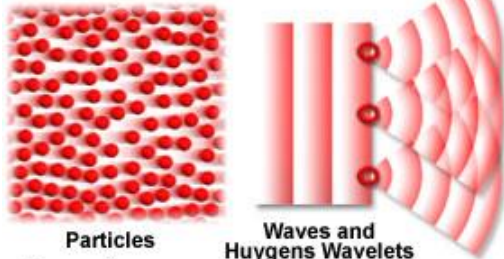

Figure 1

Refraction of Particles and Waves

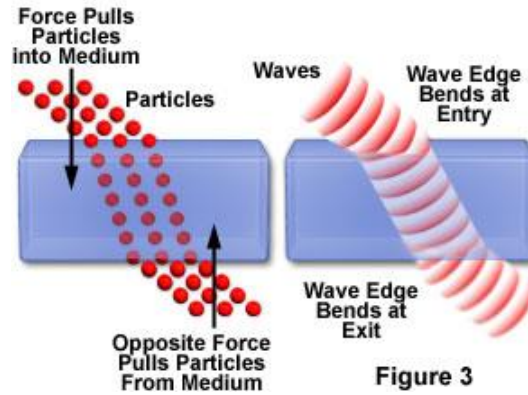

Figure 3

Diffraction of Particles and Waves

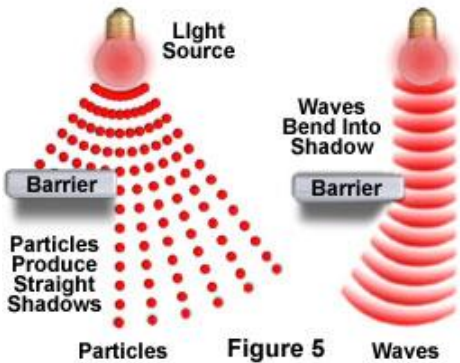

Figure 5

Young's Double Slit Experiment

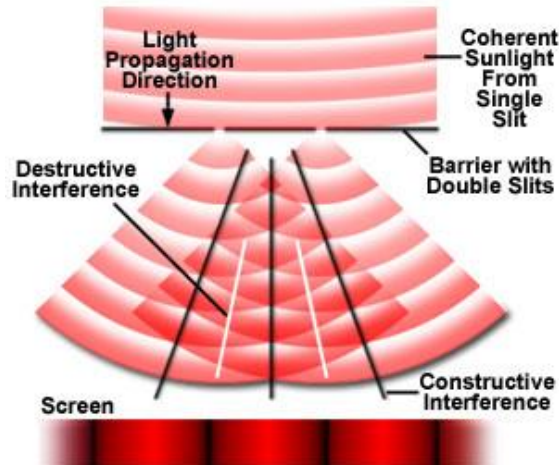

Figure 6

Intensity Distribution of Fringes

The Photoelectric Effect

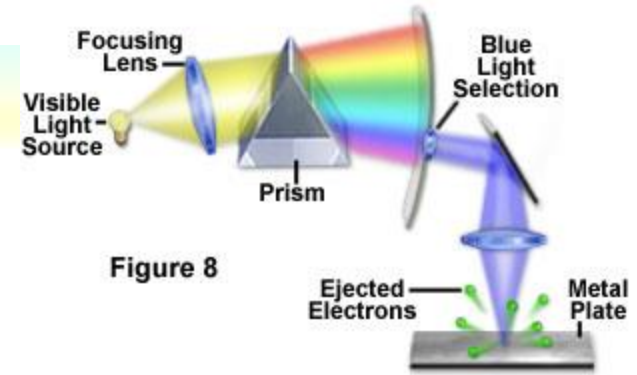

Figure 8

Particles and Waves Reflected by a Mirror



Particles

Figure 4

Waves

Particles and Waves Through Crossed Polarizers

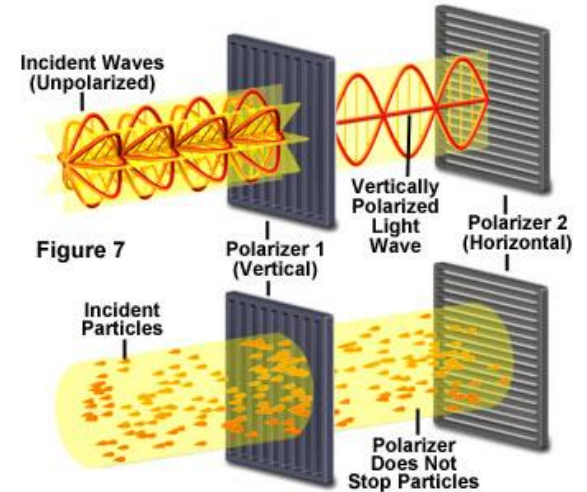

Figure 7

Nature of Matter

1D

Second derivative with respect to X

Shrodinger Wave Function

$$\frac{\partial^2 \psi}{\partial x^2} + \frac{8\pi^2 m}{h^2} (E - V) \psi = 0$$

Position

Energy

Potential Energy

3
D

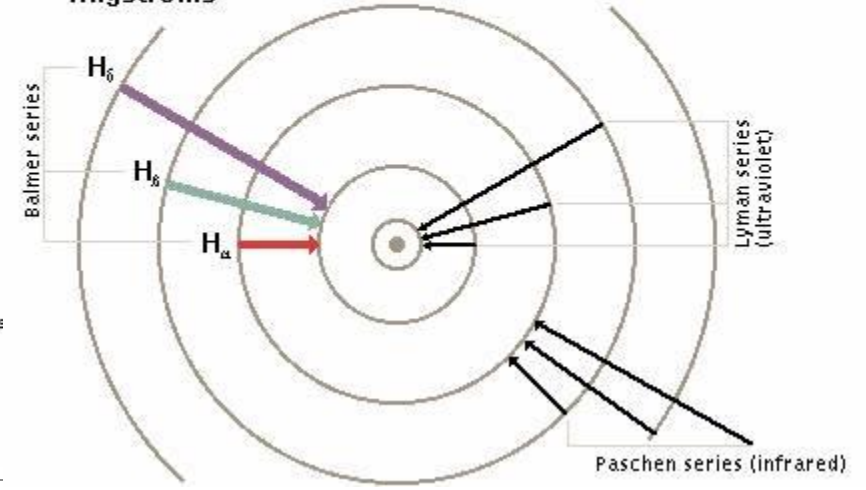
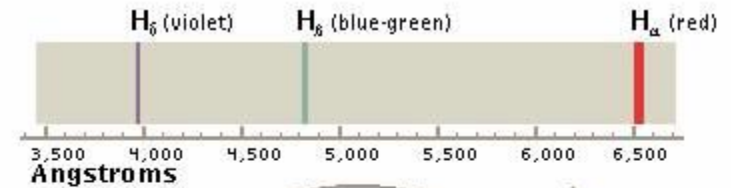
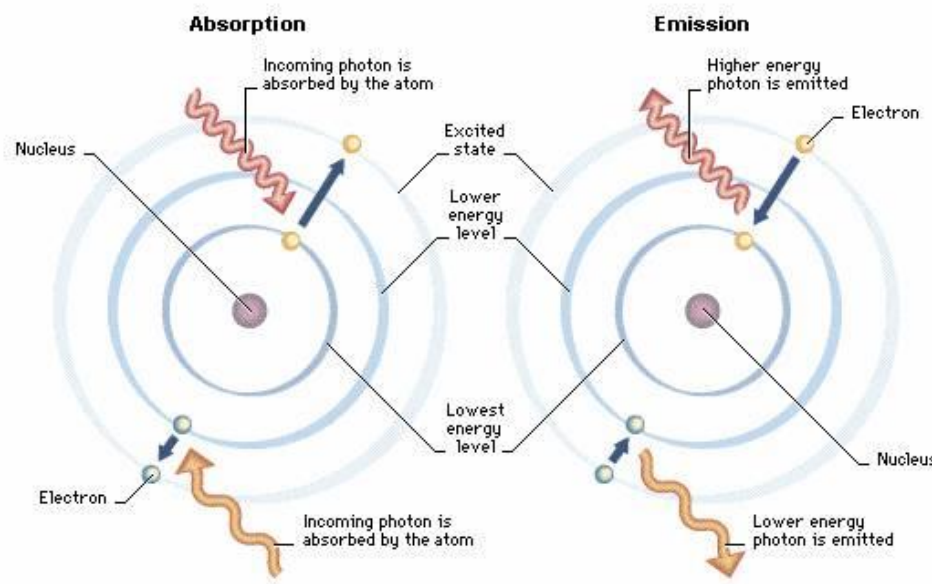
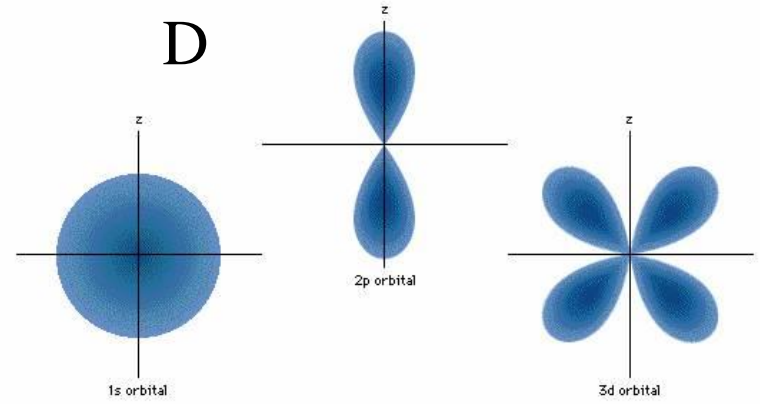

Types of Semiconductors

1. Intrinsic
2. n-type
3. p-type

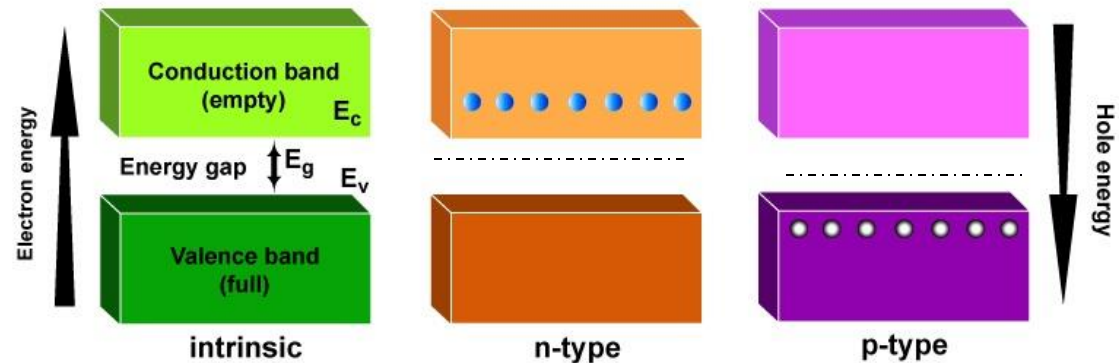

- Types 2 and 3 are semiconductors that conduct electricity - How?
 - by alloying semiconductor with an impurity, also known as **doping**
 - carriers placed in conduction band or carriers removed from valence band.

APPLICATIONS OF LED

ILLUMINATION



LED Magazine

SIGNS & DISPLAYS



TRAFFIC SIGNALS



Philips Lumileds' Luxeon LED chips, which incorporate a flip-chip design, already illuminate architectural attractions such as the Clifton Suspension Bridge in Bristol, UK, completed in 1864. The addition of the thin-film technology to Lux products will take the performance to a new level and help to initiate penetration into the residential-lighting market.

AUTOMOTIVE



Hella web site

MOBILE

OTHERS

LCD BACKLIGHT

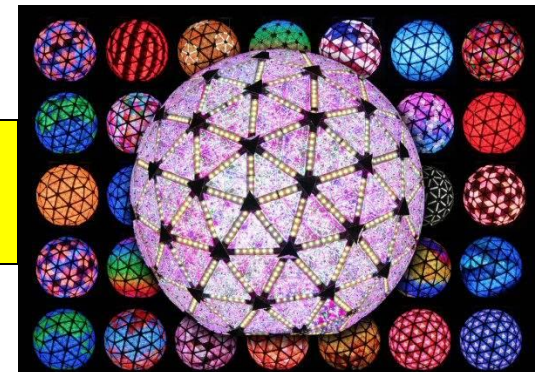

Fluorescence Principle

- A-photon absorption
- F-fluorescence (emission)
- P-phosphorescence
- S-singlet state
- T-triplet state
- IC-internal conversion
- ISC-intersystem crossing

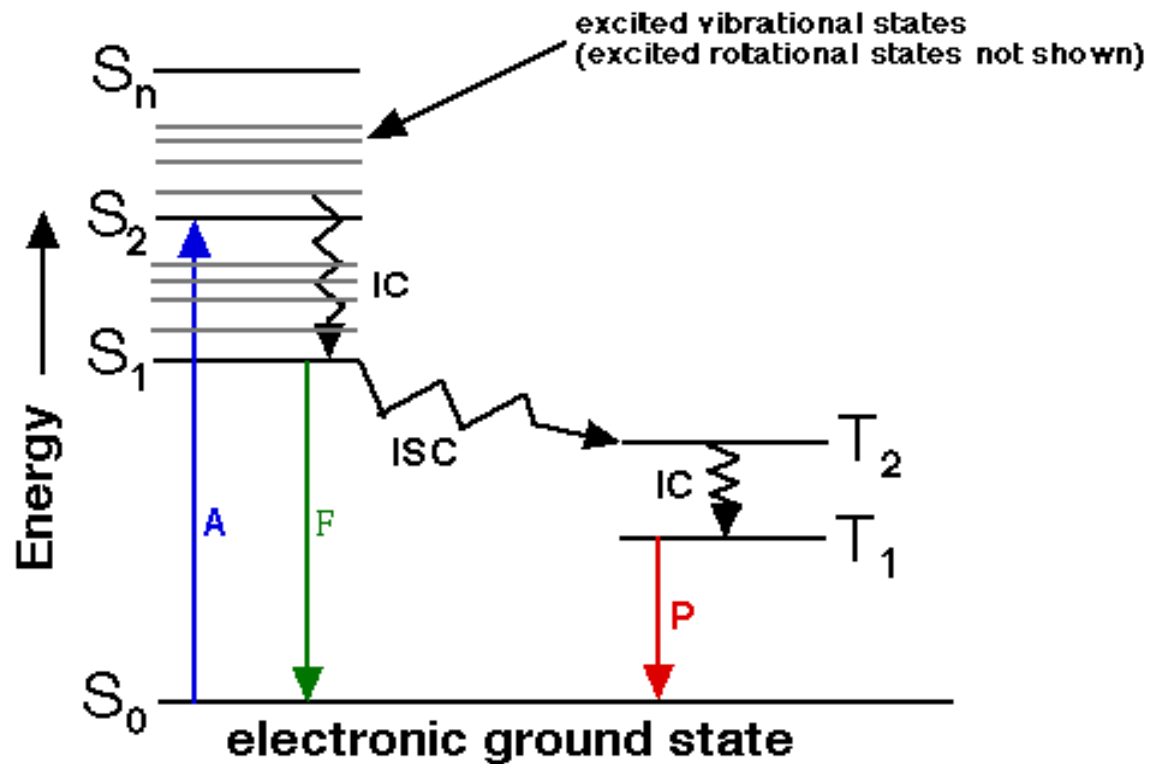

Molecular Orbital (MO)

π Molecular Orbitals of Ethene

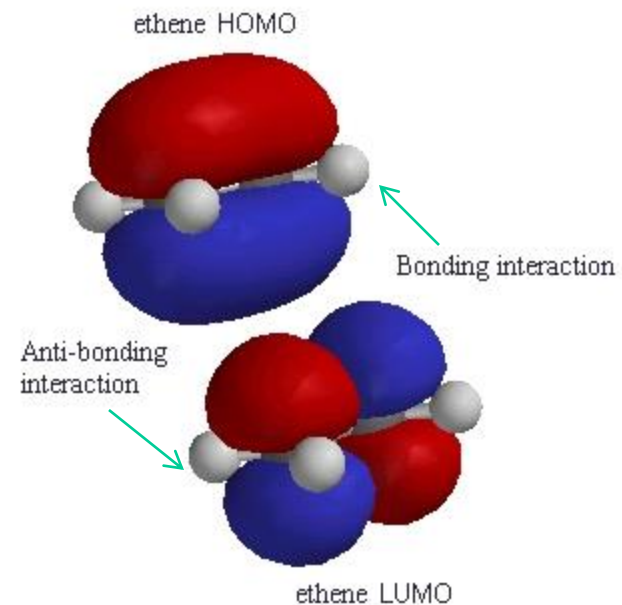
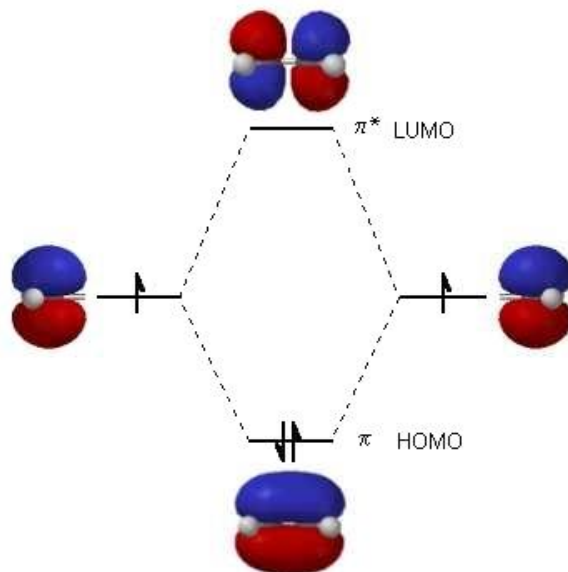
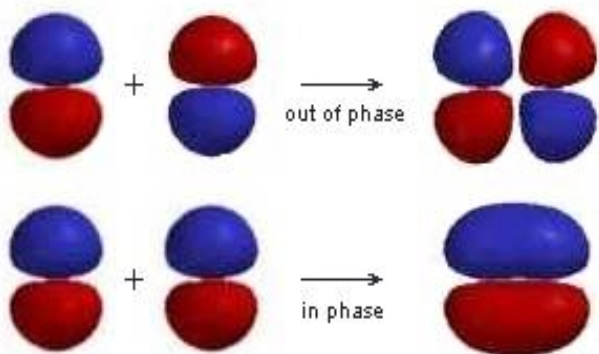
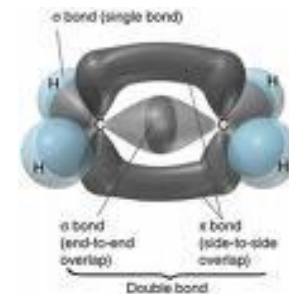
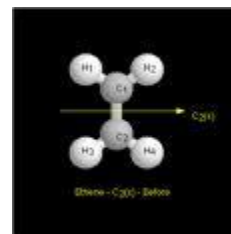
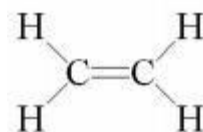

Partition of Molecular Schrodinger equation

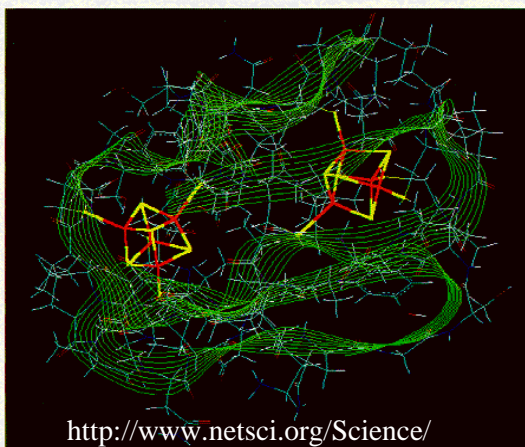
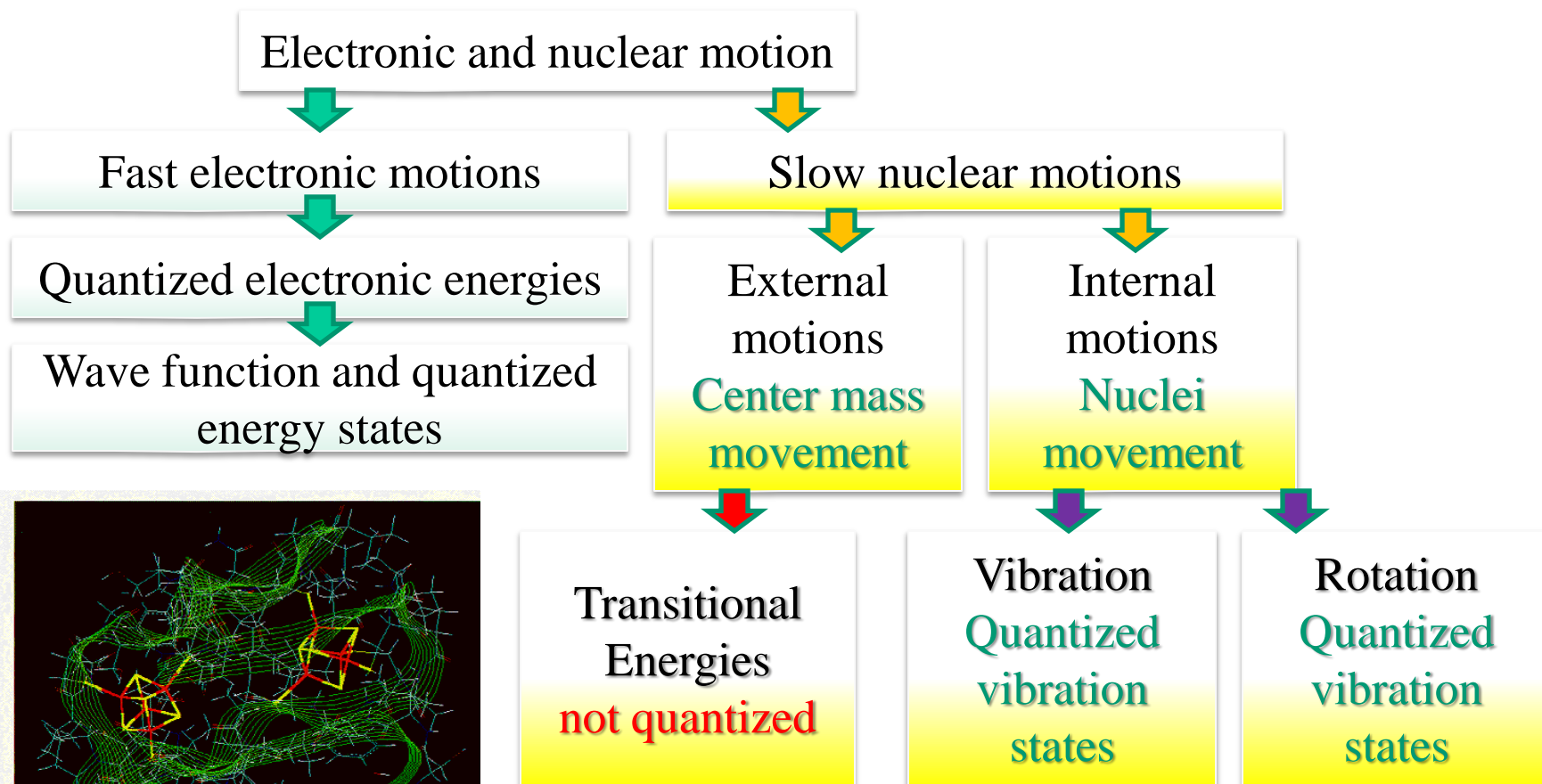

THE COMPLETE DIGITAL SOLUTION

Analog LCD

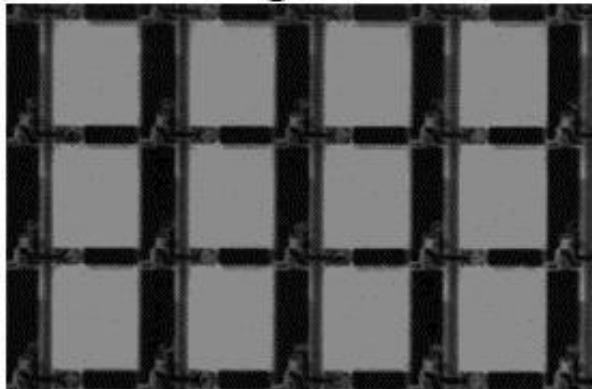

Digital DLP™

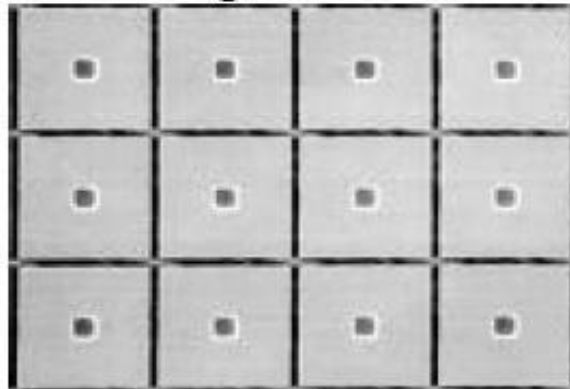

See the Digital Difference!

DMD = TWO Major Architectures

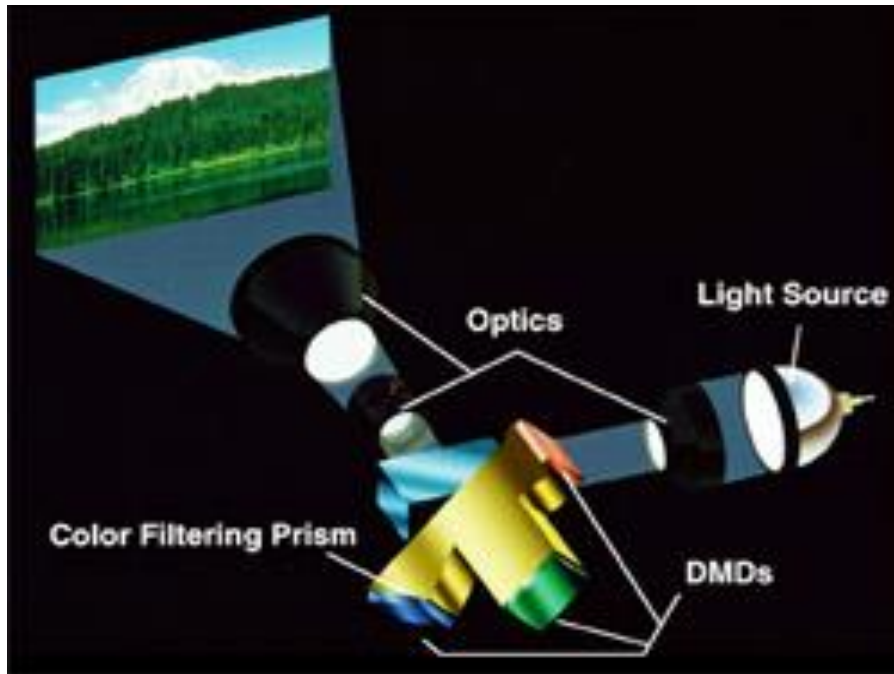

3 DMD

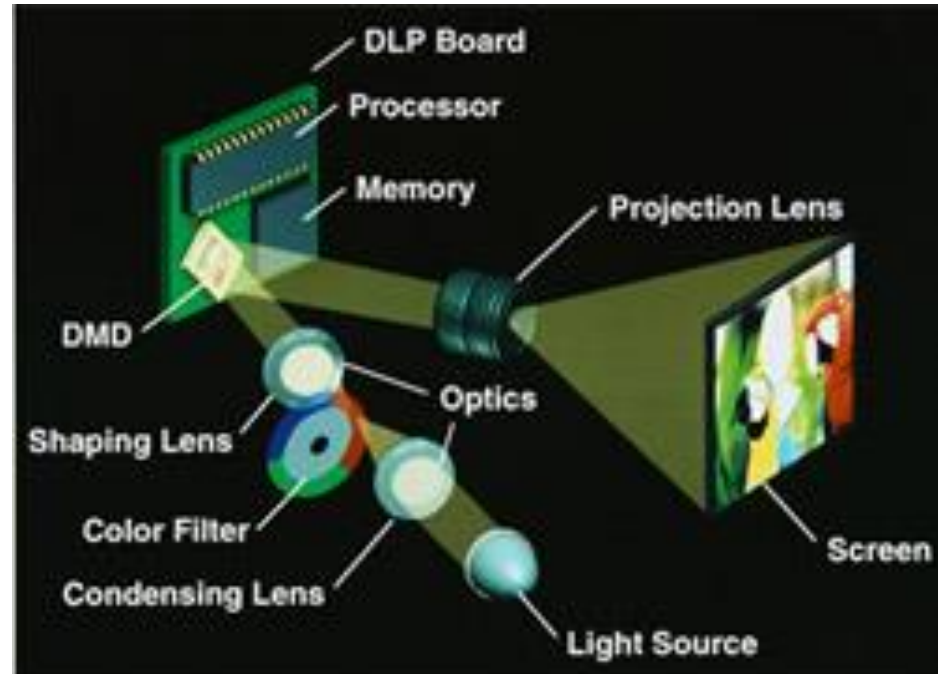

1 DMD

Two DMD pixels (mirrors shown as transparent).

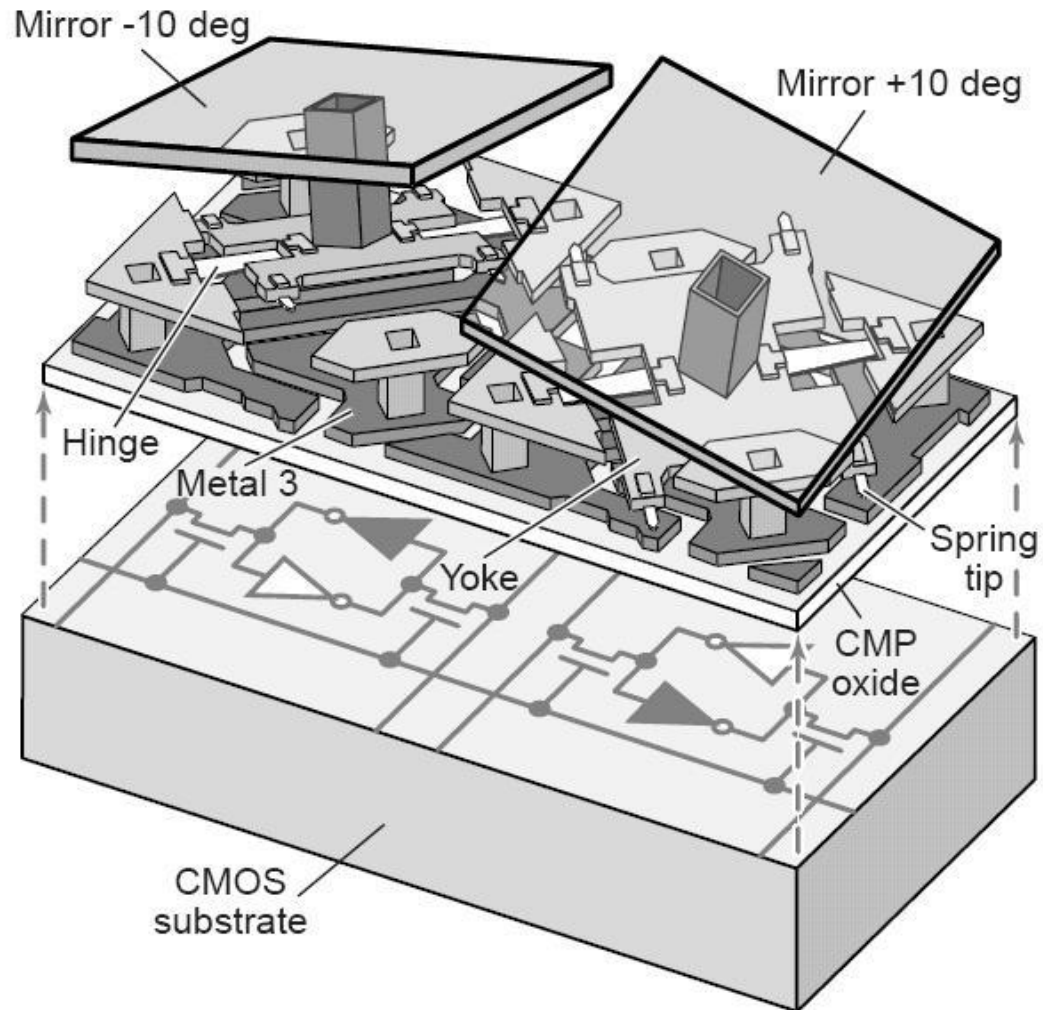

DMD SCR (Sequential Color Recapture) Wheel

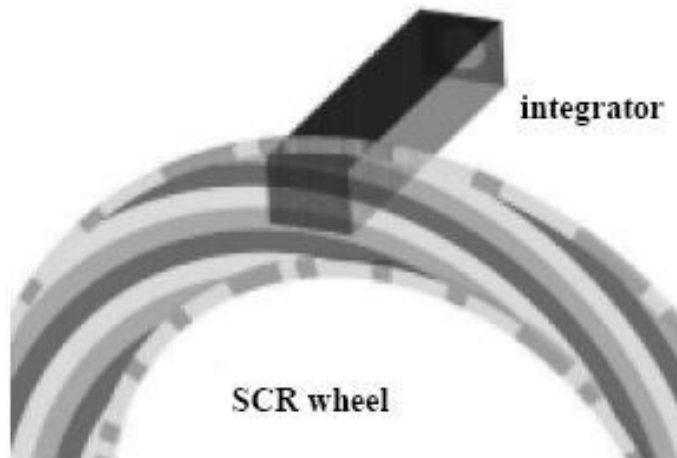
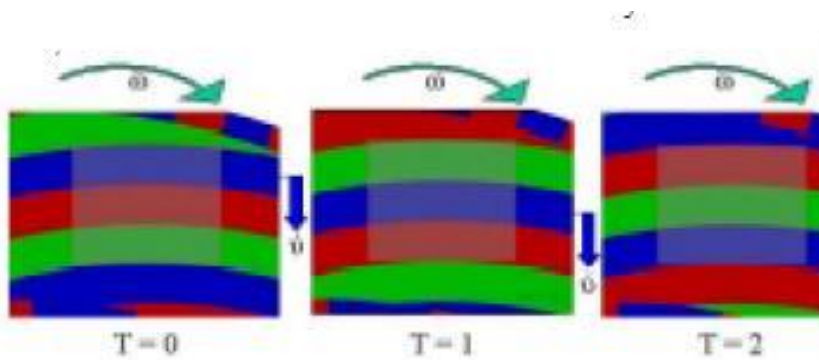

SCR Wheel

Grating Light Valve ™ Display

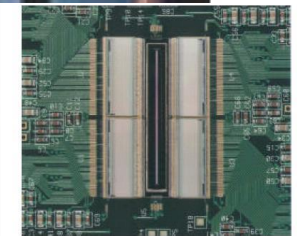

Multi-chip module consisting of four custom driver dies and a 1,080 element linear GLV array.

An HDTV-resolution projector utilizing three GLV device optical attenuator modules

Grating Light ValveTM

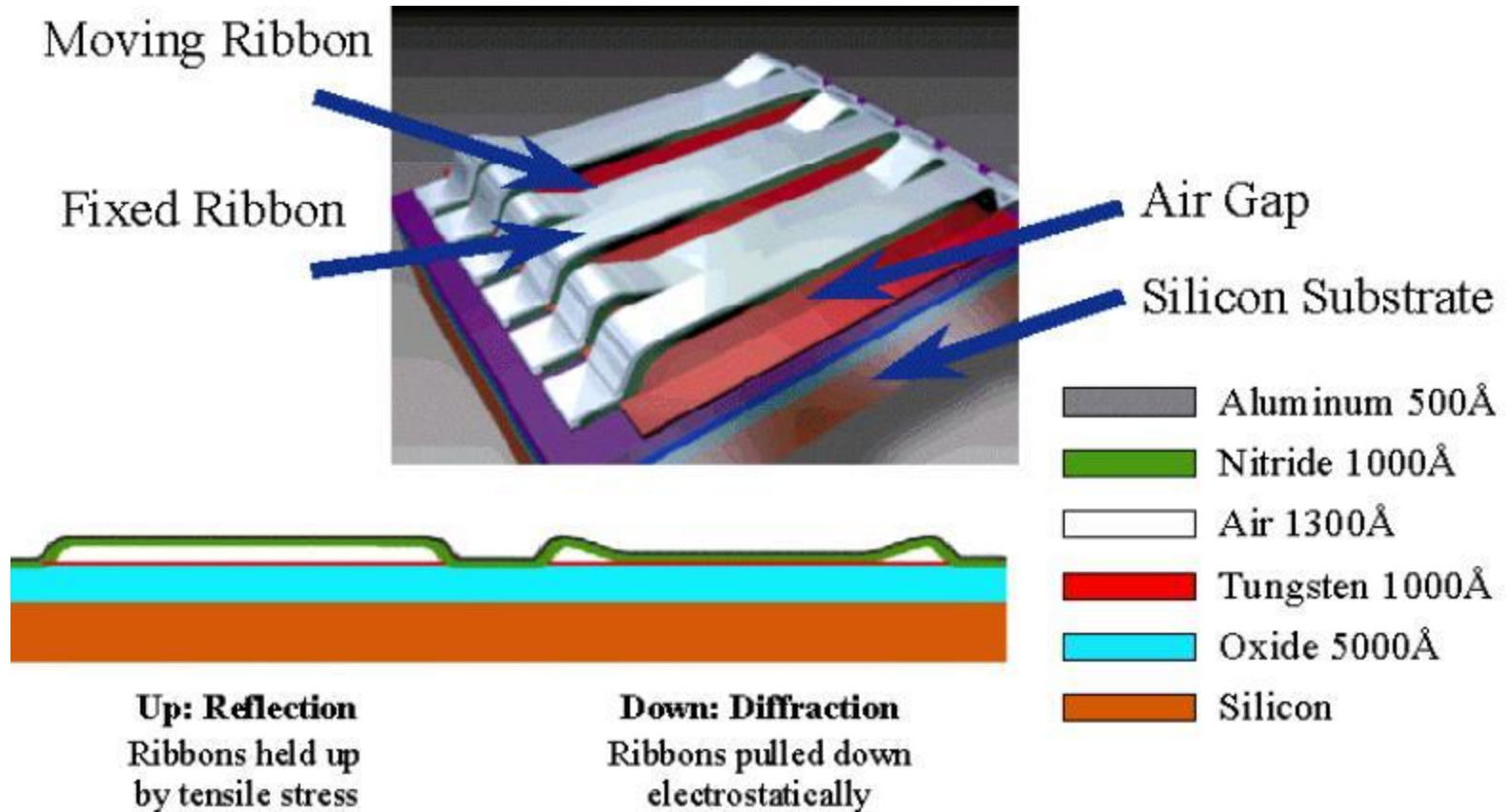

Principle

- GLV devices are unique in that they operate as mirrors in the “OFF” state, and as diffraction gratings in the “ON” state — with the application of control voltages.

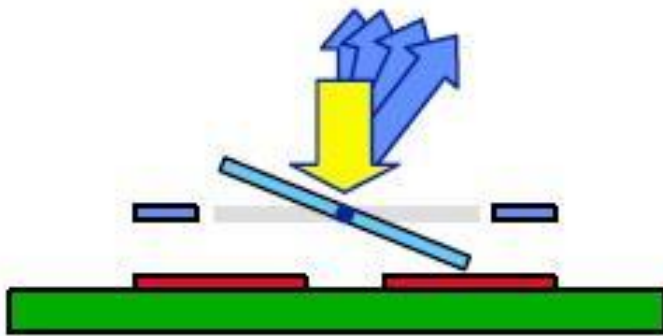

Tilting Mirror Optical MEMS

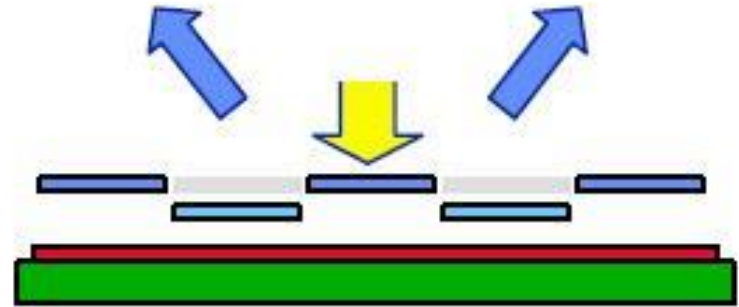

GLV Diffraction Grating MEMS

Colorization

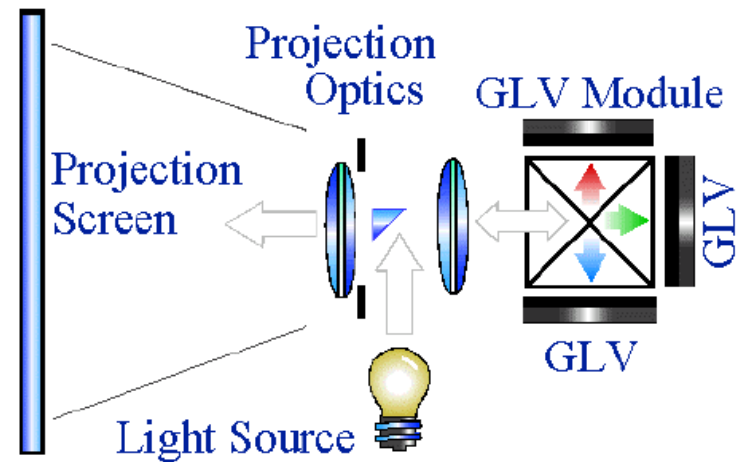
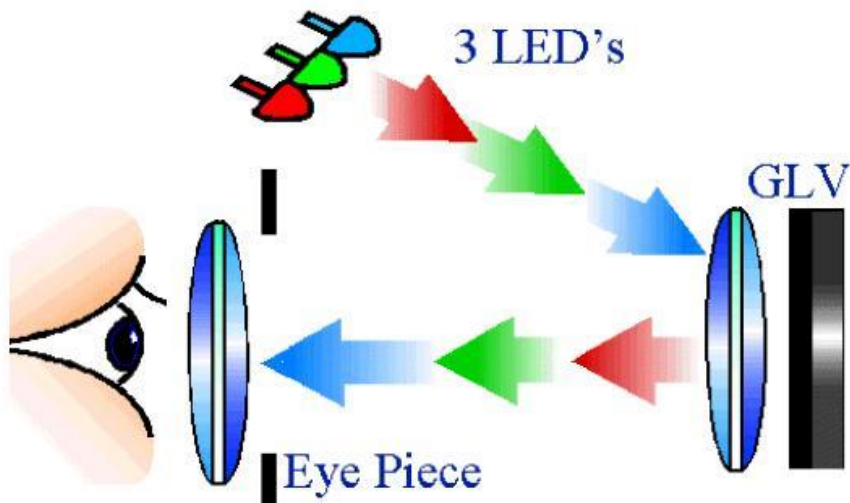
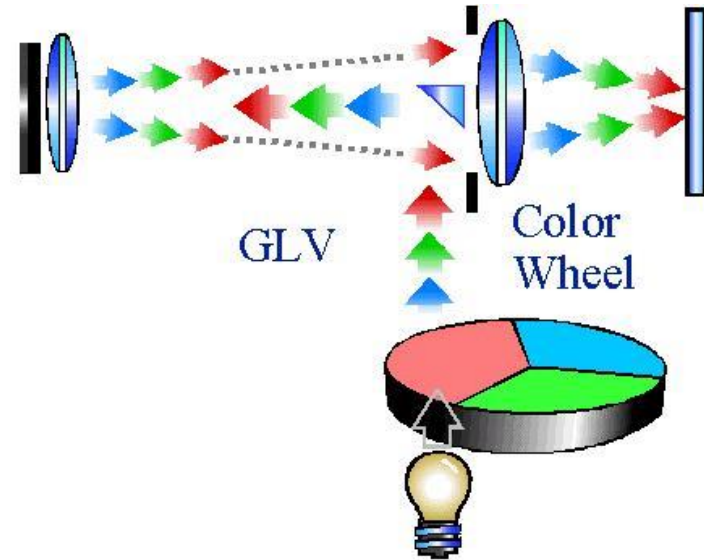
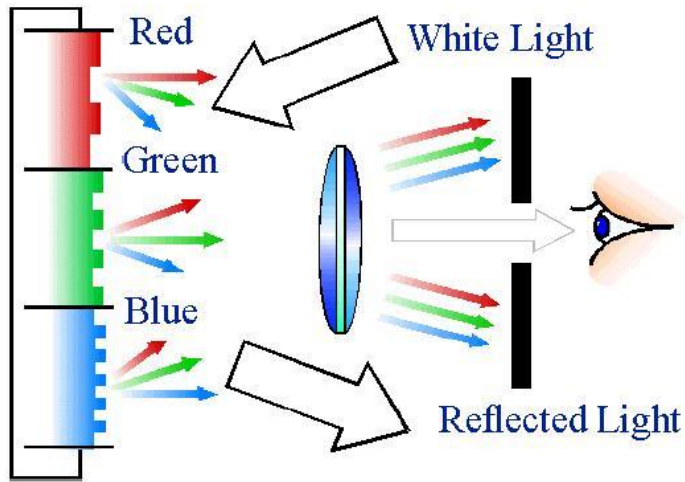

Inspired by Nature



Revolutionary Display Technology—Inspired by Nature

Principle

Replicating the Beauty of Mother Nature

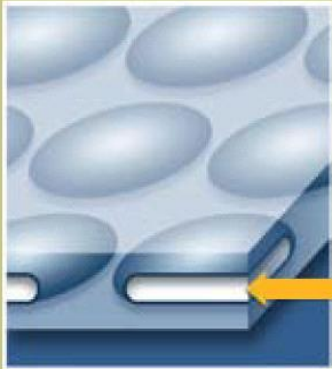

Butterfly wings



IMOD display

The Interferometric Modulator (IMOD) Element Has Built-in Memory

- 1
- 2
- 3
- 4

The IMOD element is held in an open state by applying a constant bias voltage.

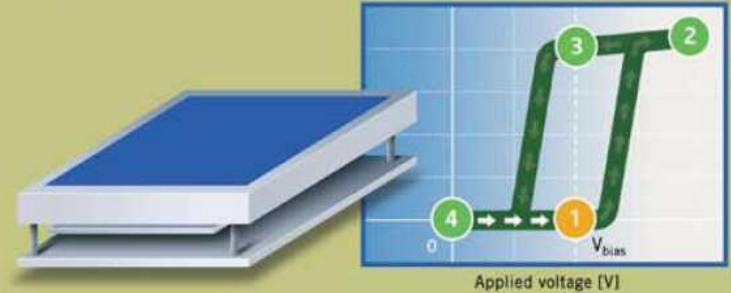

- 1
- 2
- 3
- 4

A short positive-going "write" voltage pulse is applied, causing the membrane to be driven into a collapsed state.

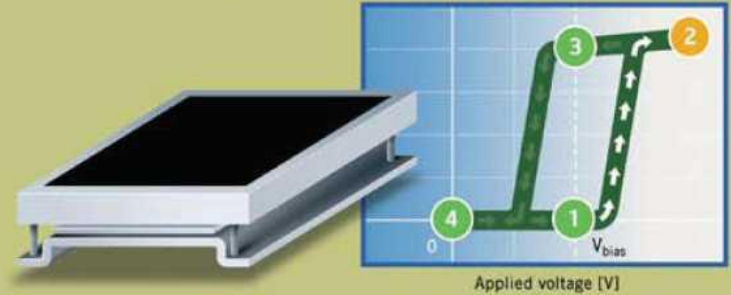

- 1
- 2
- 3
- 4

After the "write" pulse is removed, the IMOD element stays in the collapsed state with the application of the constant bias voltage.

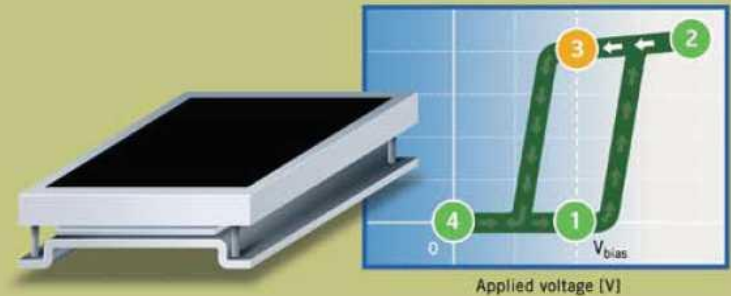

- 1
- 2
- 3
- 4

A short negative-going "unwrite" voltage pulse is applied, causing the membrane to pop back up into the open state.

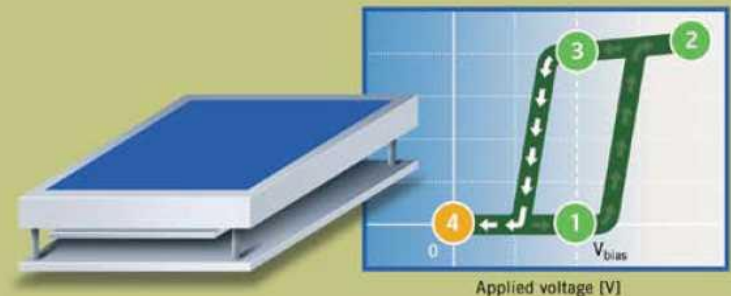

Marketing Strength



No other display technology can match QUALCOMM's clear, crisp display performance. Users get the most out of their mobile devices throughout the day—without annoying “blackouts.”

- Even in intense early-morning sunlight, sports monitor displays are easily viewable during a daily workout.
- Running errands is easier when text messages and directions can be easily viewed—inside or outside of the car.
- PDAs and MP3 displays are more useful when information can be accessed and viewed anywhere—indoors or out, enhancing enjoyment and usability.
- Even when relaxing at the park or beach, users can keep connected with easy access to messages and information.

San Diego, CA



Hsinchu, Taiwan 新竹, 台灣



San Jose, CA



- Resolution
- Readability under Sunlight

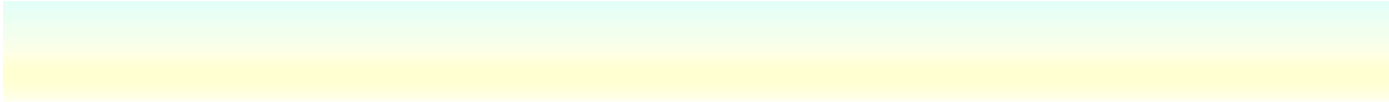

Liquid Crystal on Silicon
(LOCS)
displays

History of LCOS



1973–1983: Direct-view Display

1973 Hughes Aircraft: the first LCOS device

1980 Toshiba: direct-view television screen

1981 Seiko Epson: textured diffuser mirrors

1981 Std. Telecomm: 40 × 40 dichroic

1983 Toshiba: 480 × 480 with planarized mirror



1983–1998: Spatial Light Modulators

1983 Hughes: silicon liquid-crystal light valve

1989 Displaytech: 1st foundry silicon & FLC

1994 Displaytech: CMP

1995 Displaytech: SLM with lenslet

LOCS

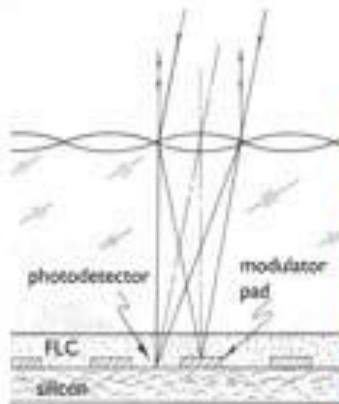
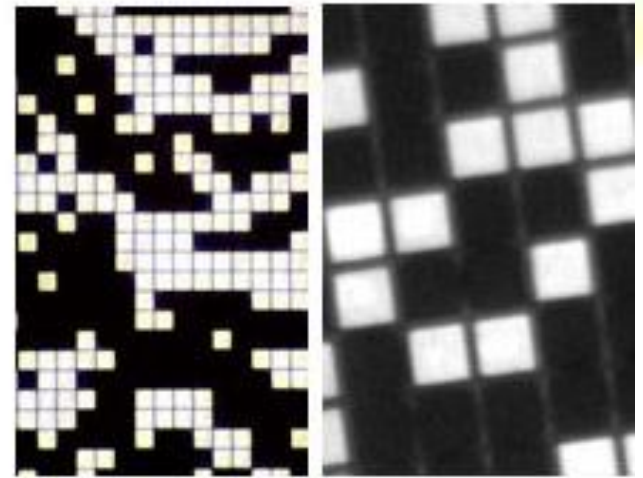
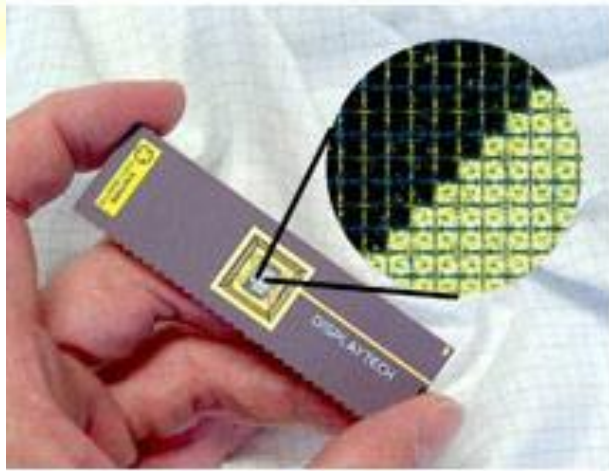

(a) schematic

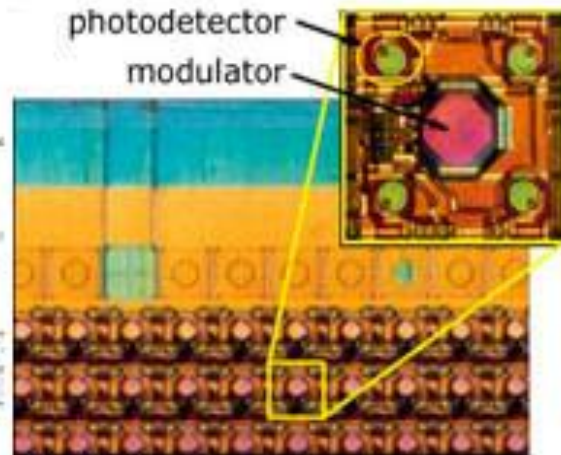

(b) SLM without lenslets.

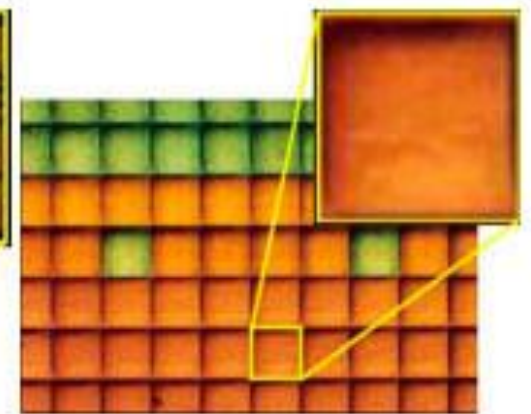

(c) SLM with lenslets.



Micro-Vision Scanning Display

Imagine.
Entertain.
Share.

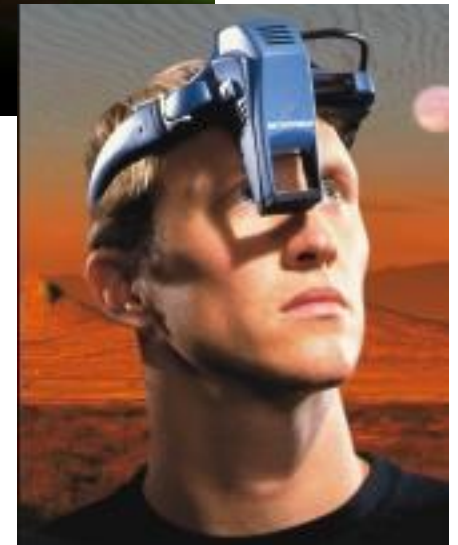



OLED=BENDABLE

SID 2007

AM, p-Si, RGB, QVGA

Substrate: metal foil

AM Backplane: LGPhilips

OLED: UDC

Barix encapsulation:
Vitex

Robert Jan Visser:SID-Display Applications Conference 2007

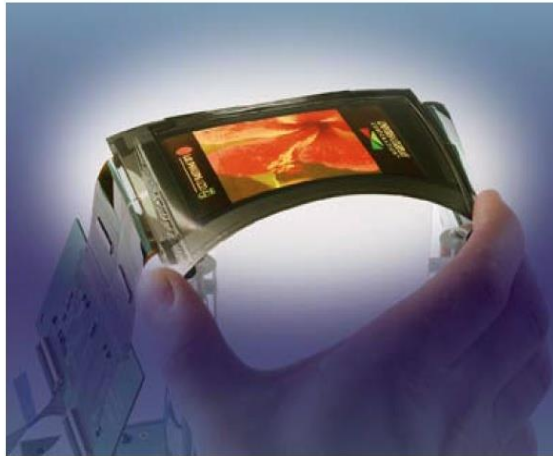

Sony 2007

OLED vs. LED

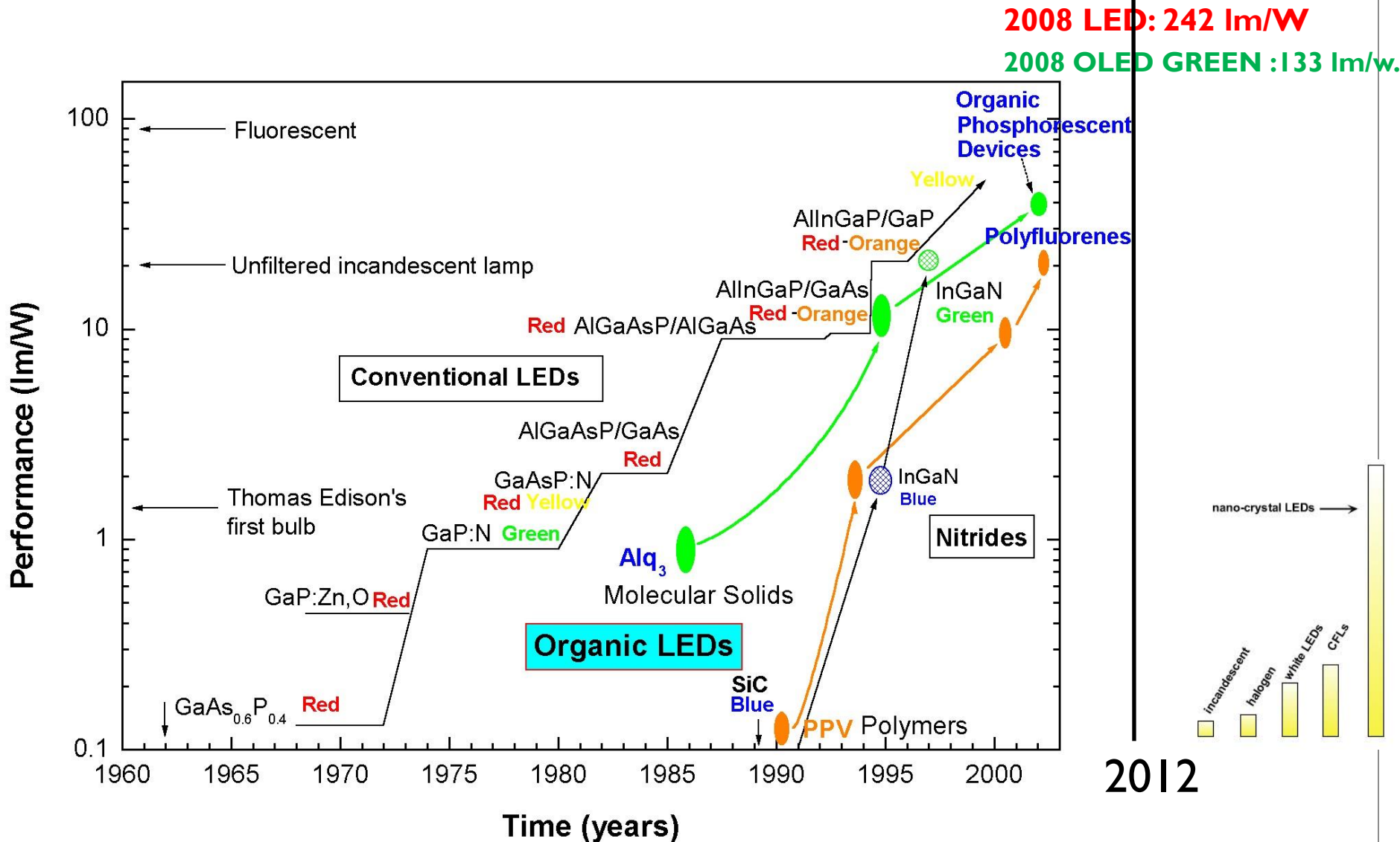

from Science 273, 884

OLEDs: Displays You Can Print

- ▶ Manufactured in small molecule (SM-OLED) and dispersed polymer (P-OLED) designs
- ▶ Both are low-voltage semiconductors that emit light when current flows through an organic film layer
- ▶ Poised to take over the handheld display market



Photo courtesy Cambridge Display Technologies

OLEDs: Displays You Can Print

- Yes, OLEDs are very, VERY thin! (< 5mm for film layer)
- Samsung 40-inch active matrix OLED shown at SID
- Polymer-based colors are developed with Dupont
- Issues remain with white balance and motion image sharpness





Recent Advances in Electronic Ink



Guniea Pig: This Digital Book by E Ink and Philips is the first major product to use electronic ink. It's slated to begin mass production in 2004.



The ol' RGB: This prototype was the first high resolution color electronic ink display. It combines E Ink's electronic ink technology with a color filter array from Toppan, and Philips' active matrix backplane.

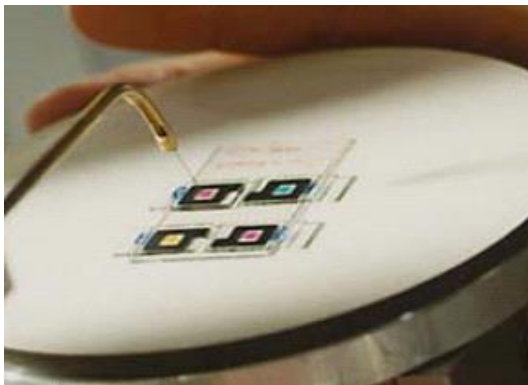
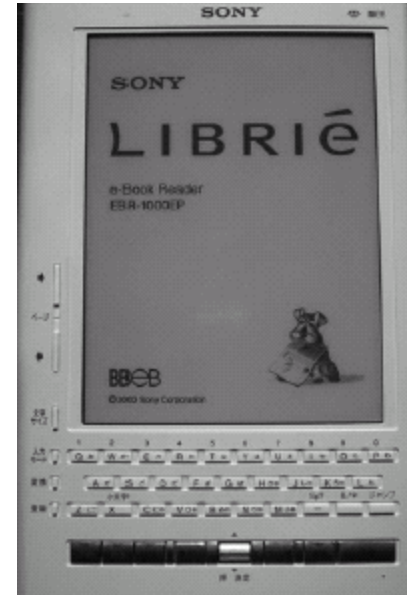

E-ink Principle

Cross-Section of Electronic-Ink Microcapsules

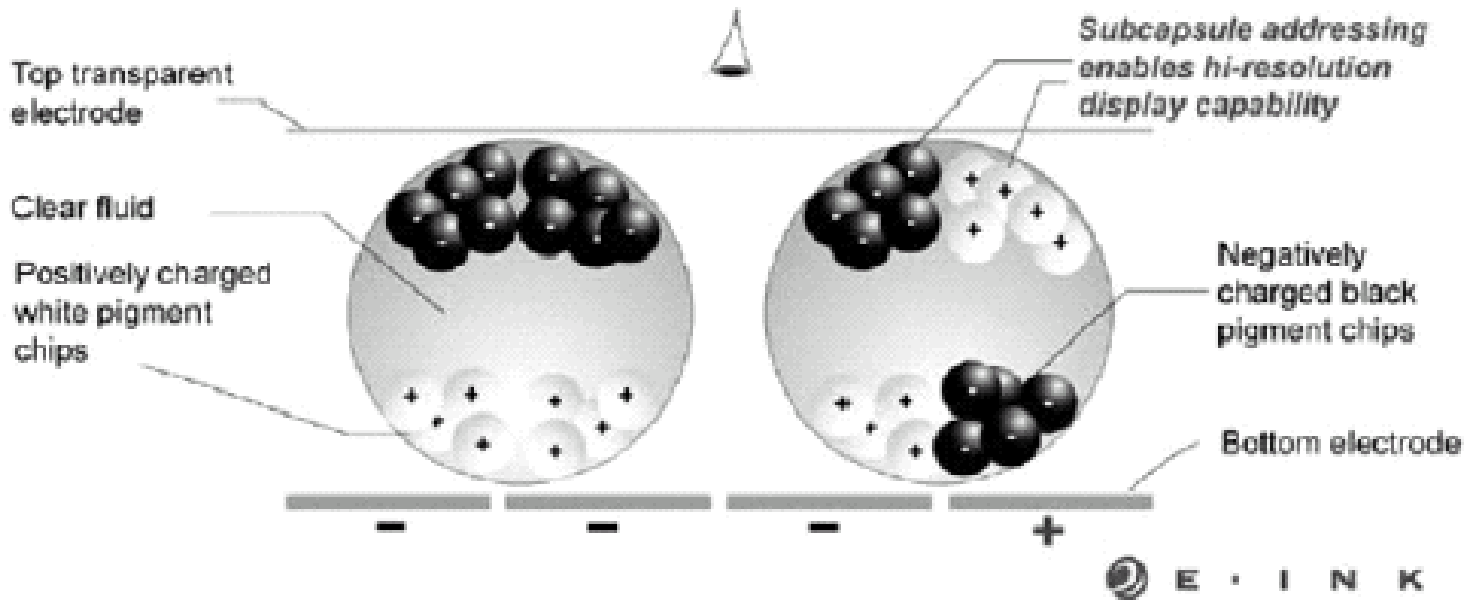

NOTE: Image not drawn to scale - for illustration purposes only.

Electro-Phoretic Displays Principle

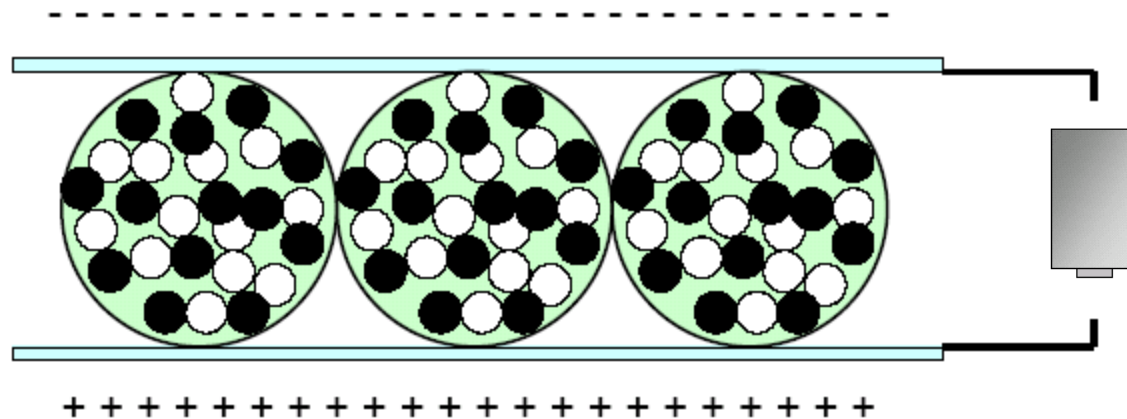

- Black and white particles are contained in micro capsules.
- Black particles are attracted to + electrode; white particles to -.
- Attracted particles remain in place even when electrodes return to neutral.

E-Ink

Electrophoretic Display Media

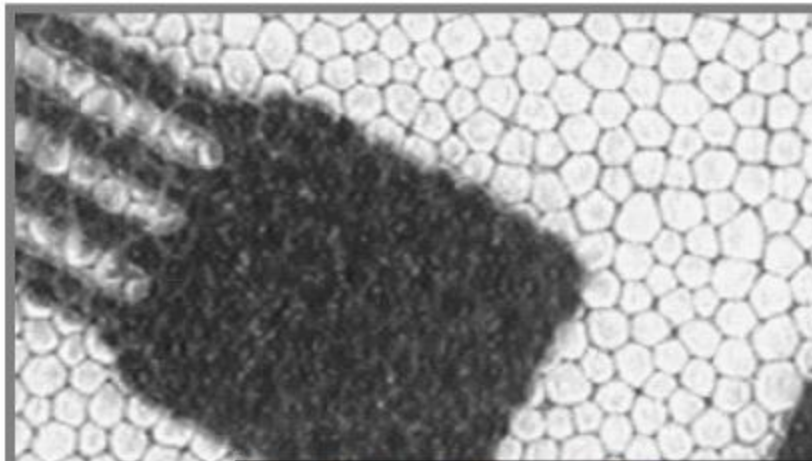

Principles of Operation

- Oppositely charged reflective submicron pigments are encapsulated in a clear liquid
- Particles move in opposite directions in an electric field
- Partial capsule imaging is possible enabling high resolution capability

Cross-Section of Electronic-Ink Microcapsules

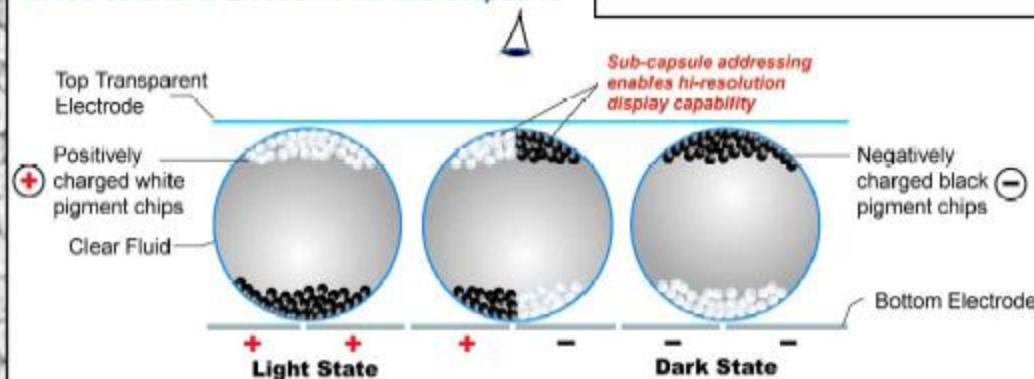

Note: For illustration purposes only - not drawn to scale. Copyright E Ink, 2003.





A staff of Citizen Watch presents a digital clock that is as thin as a piece of paper and fully flexible in Tokyo on Dec 15, 2005.

E-PAPER!

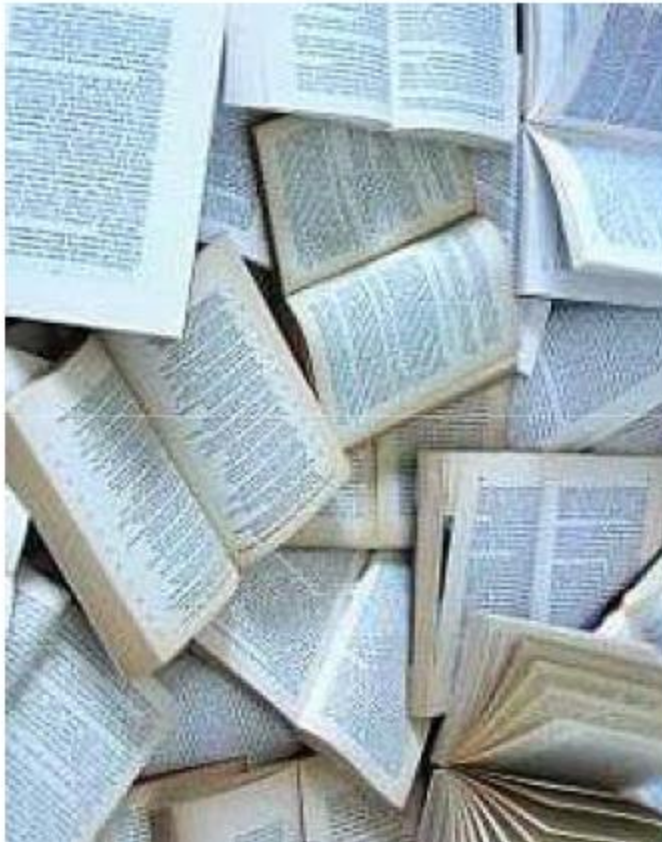

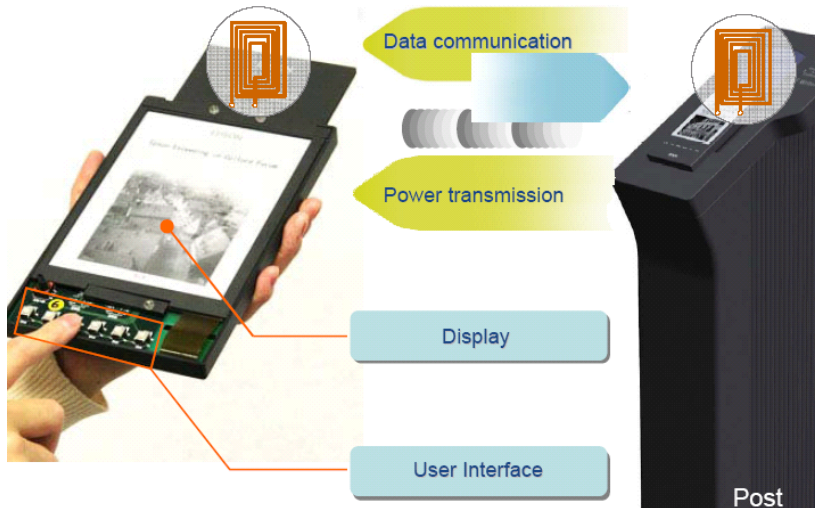

TAKE YOUR NEWS ANYWHERE

You don't have to be connected to the internet to read news with the Times Reader.

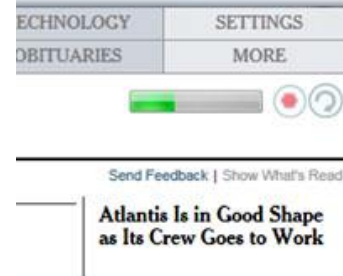

The New York Times



The portable E-guide displays appropriate information when touched to a post placed next to a museum exhibit.

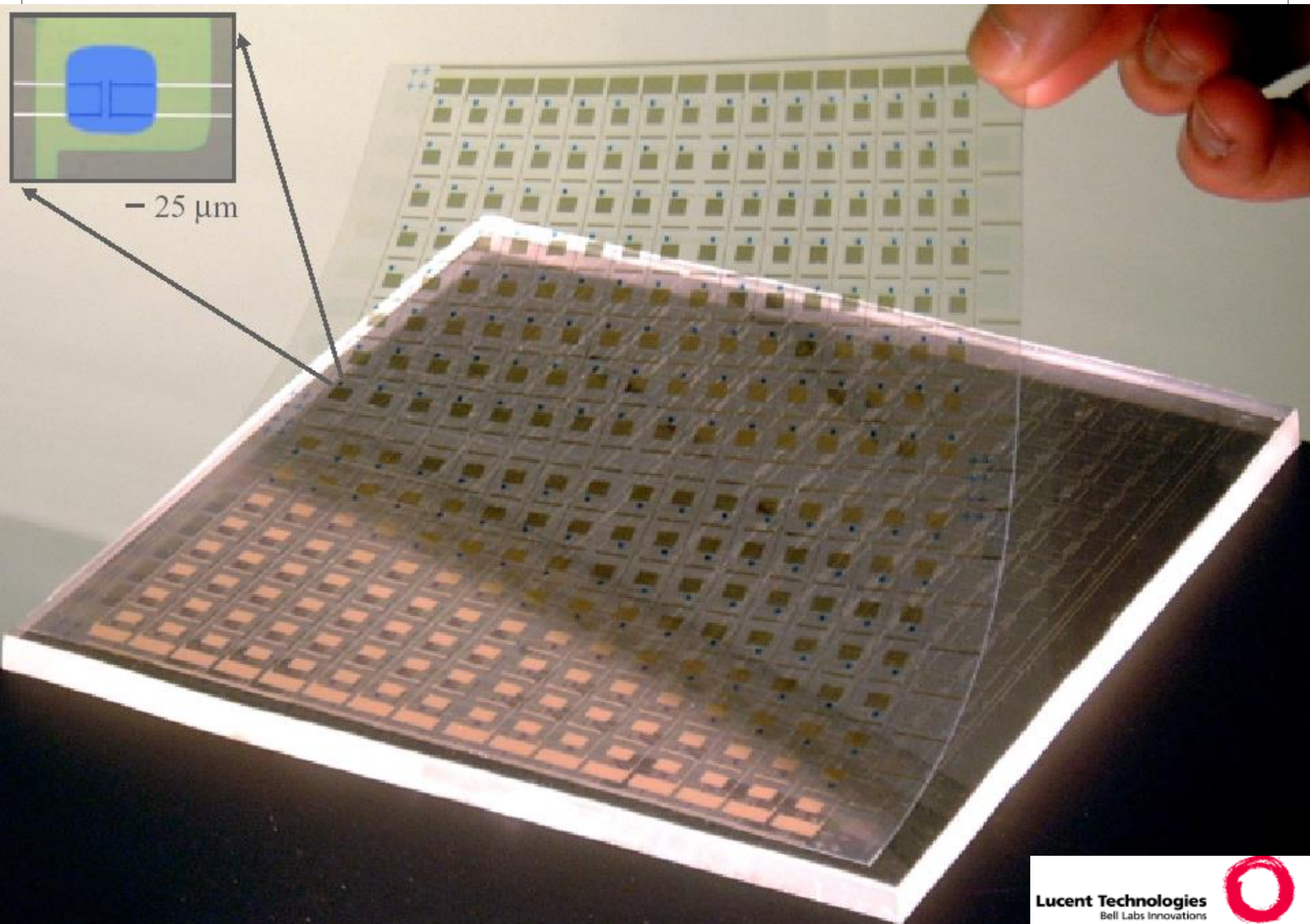

- 25 μm

The Future of Organic Electronics

NMEMS

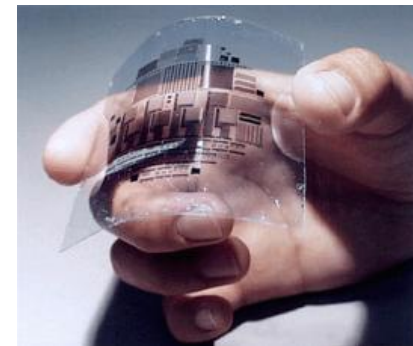
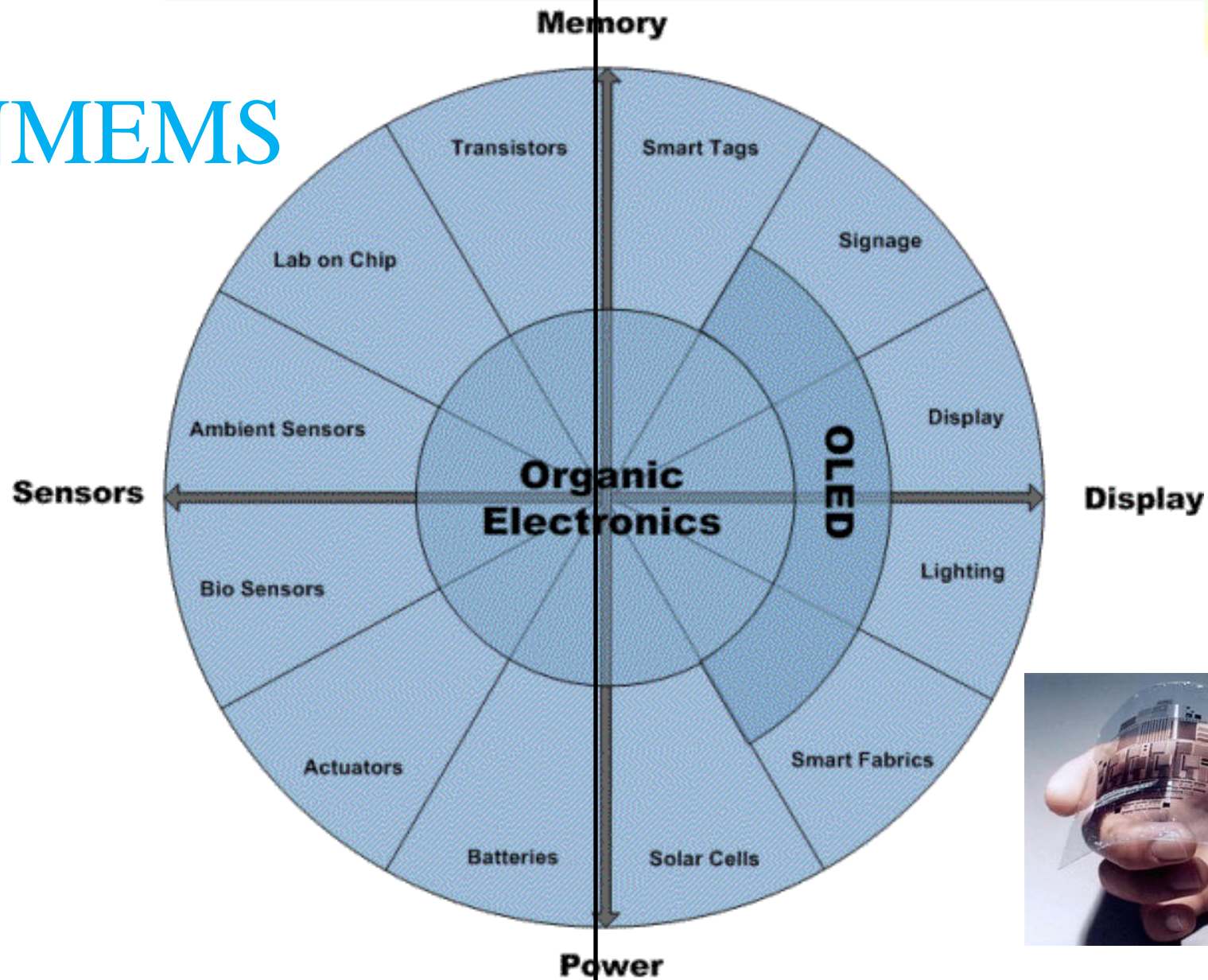

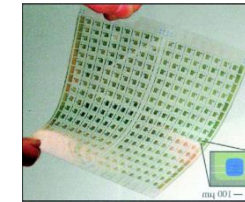
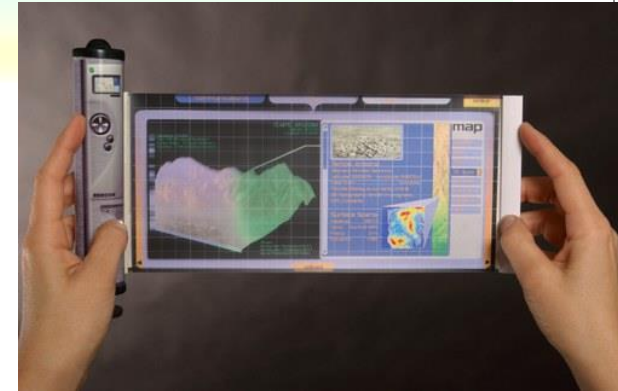
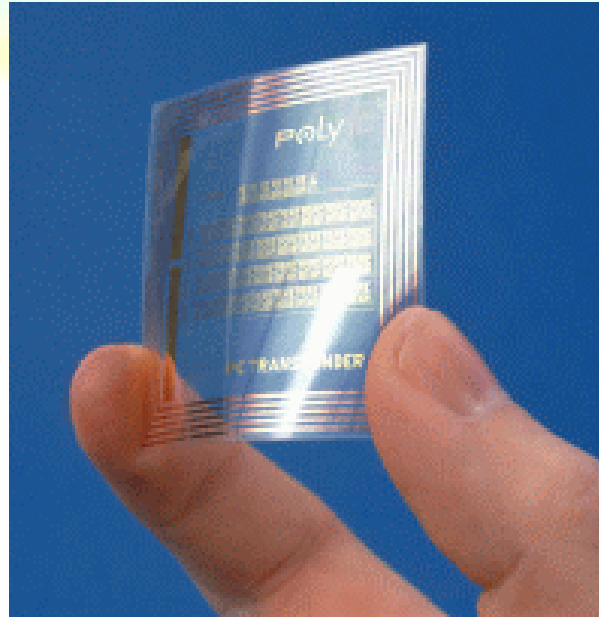
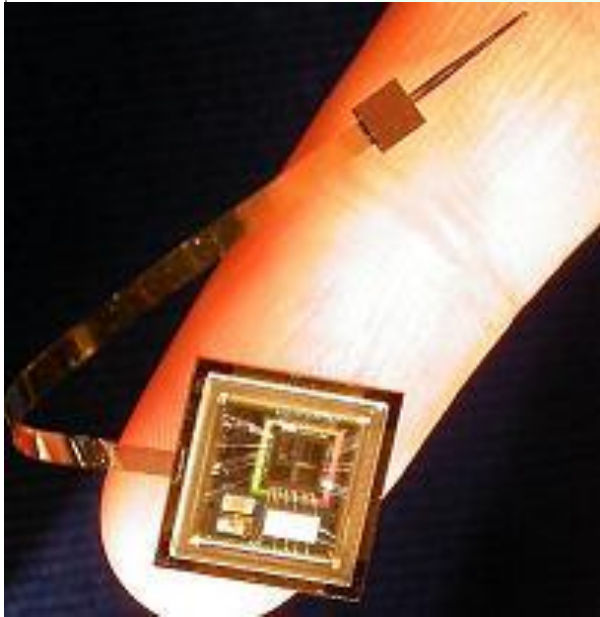

Organic Electronics

Choice of Plastic Substrate

Continuous-use Temp.	Material	Characteristics (good, OK, bad)
900°C	Steel	Opaque, moderate CTE, moderate chemical resistance, poor surface finish
275°C	Polyimide (Kapton)	Orange color, high CTE, good chemical resistance, expensive, high moisture absorption
250°C	Polyetheretherketone (PEEK)	Amber color, good chemical resistance, expensive, low moisture absorption
230°C	Polyethersulphone (PES)	Clear, good dimensional stability, poor solvent resistance, expensive, moderate moisture absorption
200°C	Polyetherimide (PEI)	Strong, brittle, hazy/colored, expensive
150°C	Polyethylenenaphthalate (PEN)	Clear, moderate CTE, good chemical resistance, inexpensive, moderate moisture absorption
120°C	Polyester (PET)	Clear, moderate CTE, good chemical resistance, inexpensive, moderate moisture absorption

⇒ Best candidates: PEN, PET

General Trends for Process



Thin Film Batch

Printed Batch

Printed R2R

photolithography

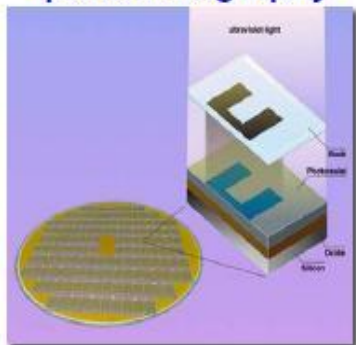

IBM



Screen Printing
web or sheet fed
simple
(Princeton, UCSC, UCLA)

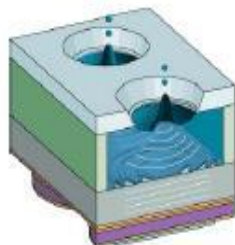

AIP printhead - PARC

Jet-Printing
digital imaging
flexible substrates
direct-write of materials
(PARC, Plastic Logic)

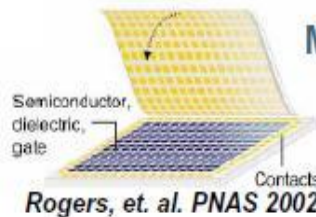

Microcontact Printing
small features
rapid patterning
(Harvard, Bell Labs, IBM)

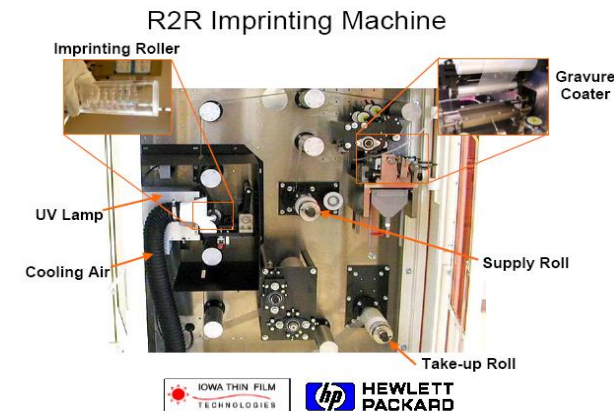

Roll-To-Roll Manufacturing

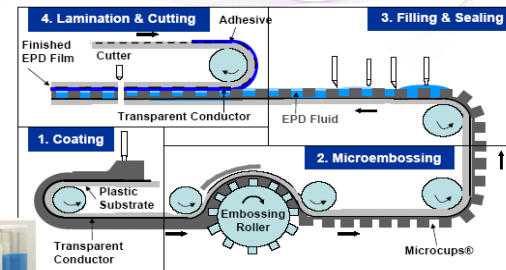

Challenges: materials compatibility, feature sizes, registration, process development



parc



Flexible display technologies

	Small Size	Big Size	Long Life	Full color	Video motion
OLED	yes	no	no	yes	yes
LCD	yes	no	yes	yes	no
Electrophoretic E-Ink	yes	yes	yes	yes	no
Plasma	no	yes	yes	yes	yes

[125-inch flexible plasma display just 1mm thick](#)

Friday, May 16th 2008 by [Chris Davies](#)

[Shinoda Plasma](#)

Display

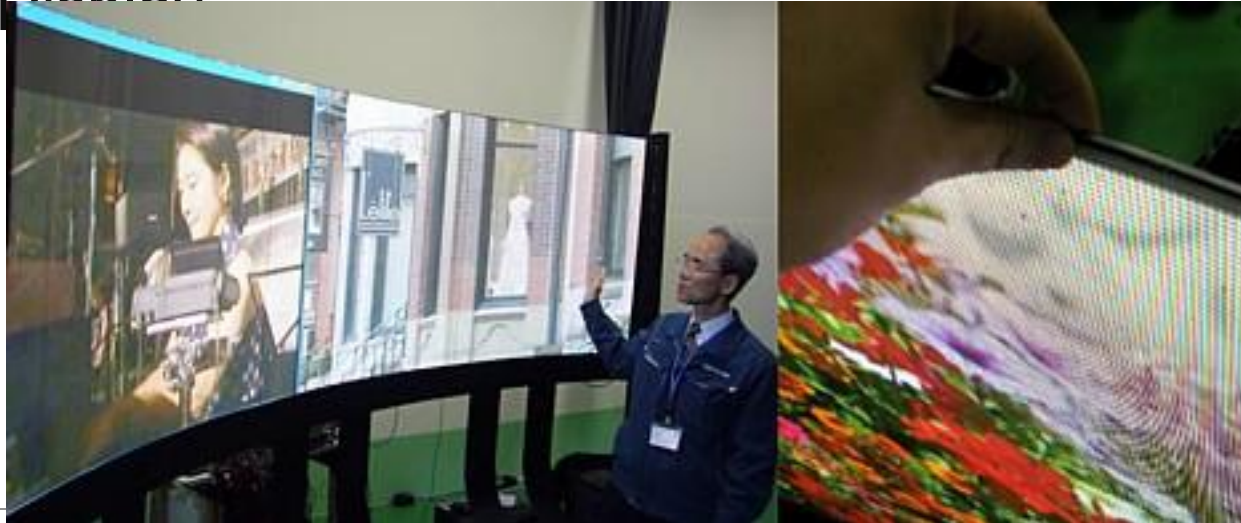

3.8" Electrophoretic Display



3D Display Technologies

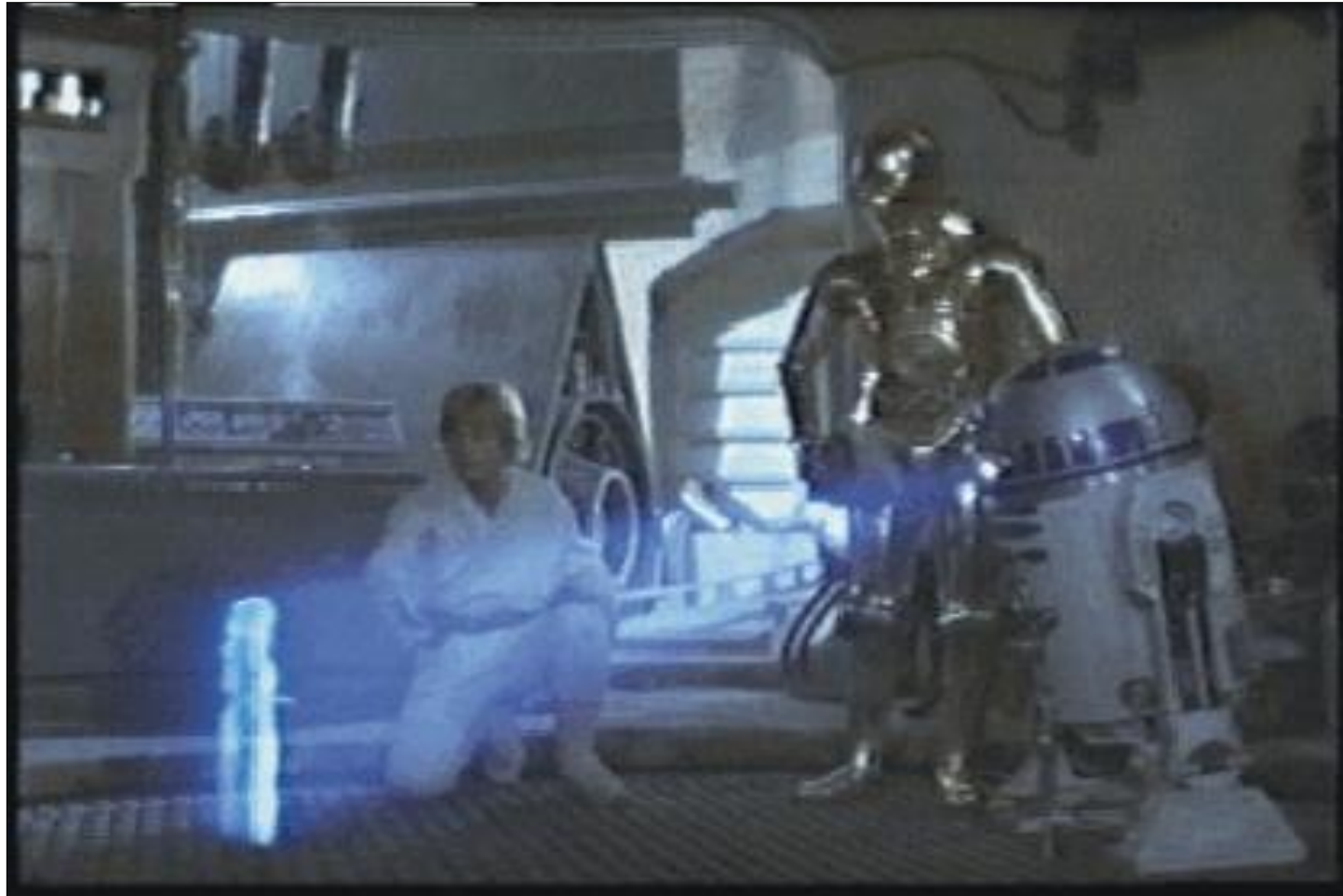

View in 3D

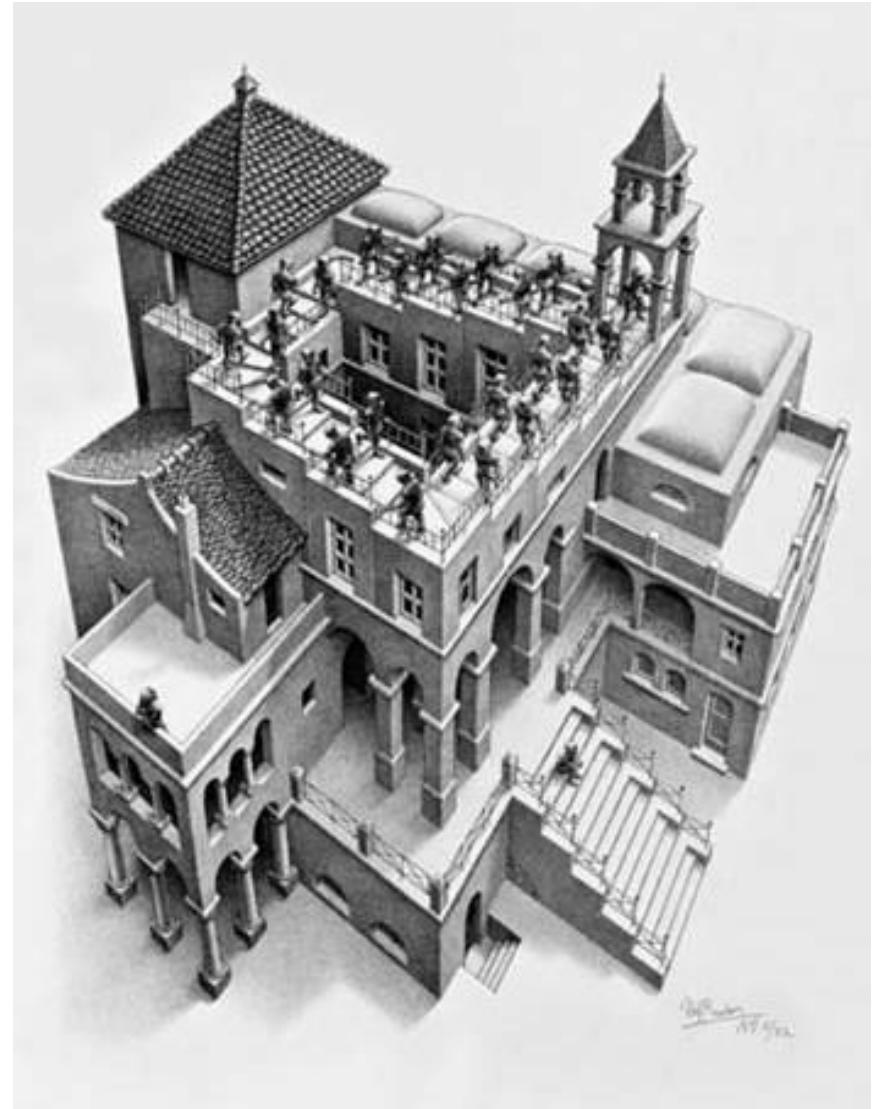
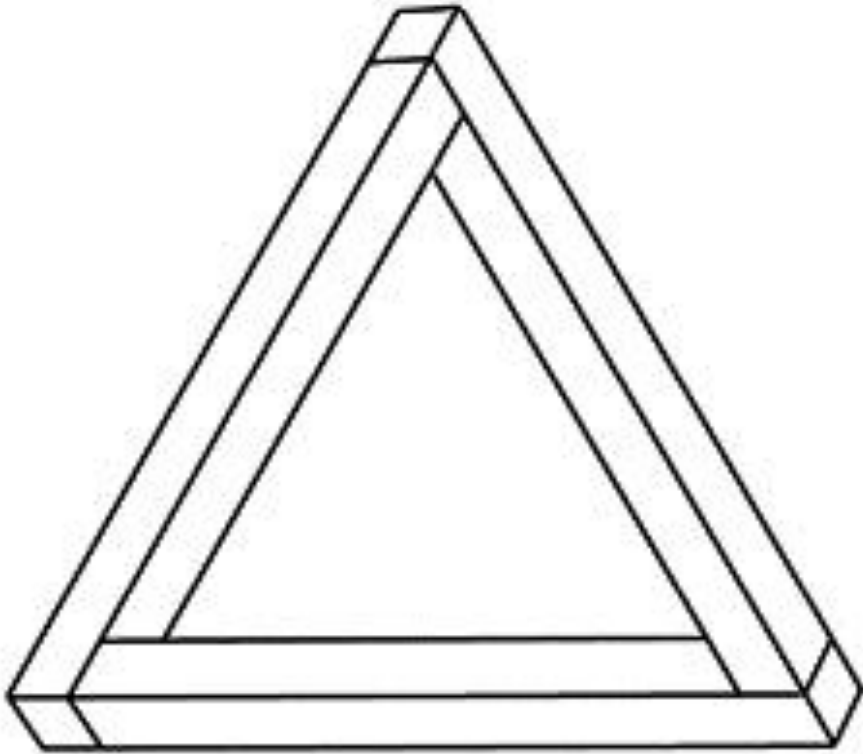

What can you find?

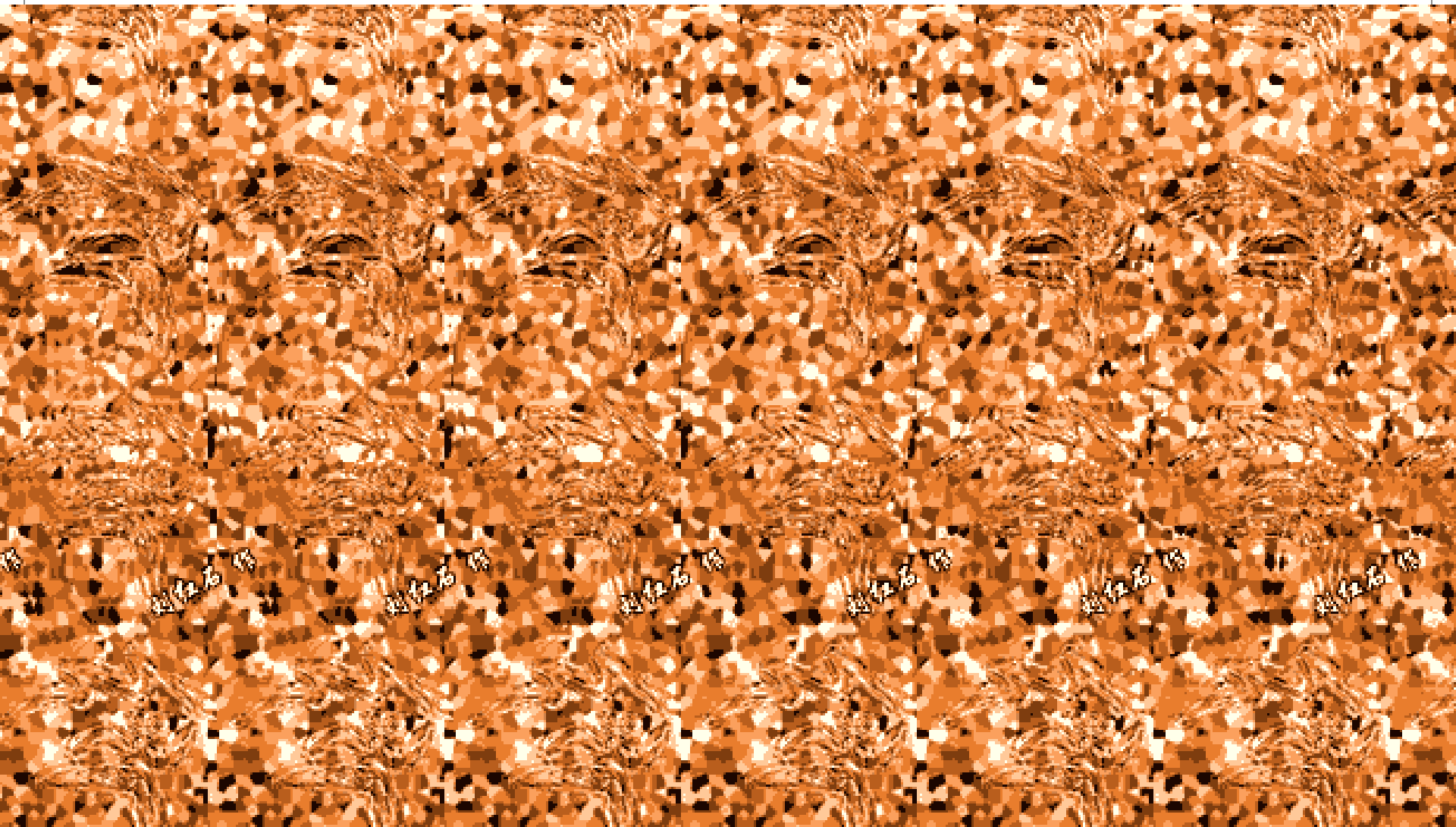

What can you find?

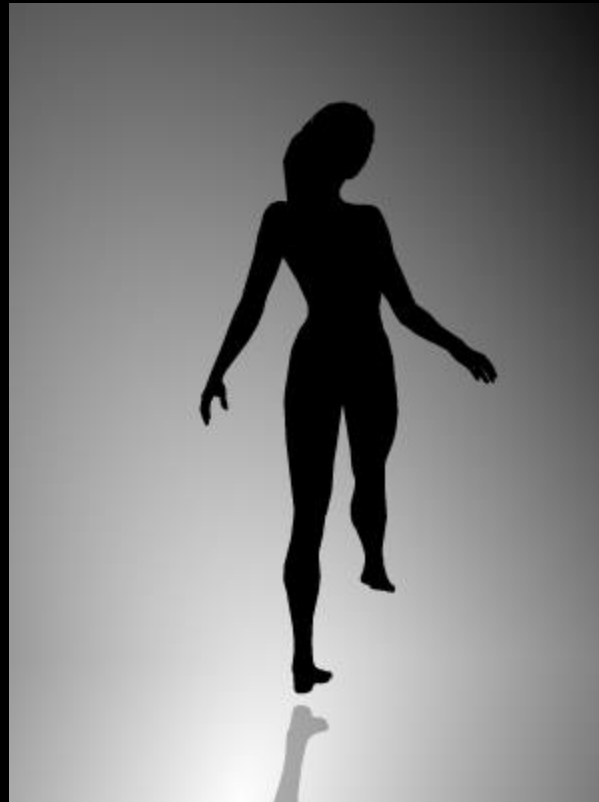

What can you find?

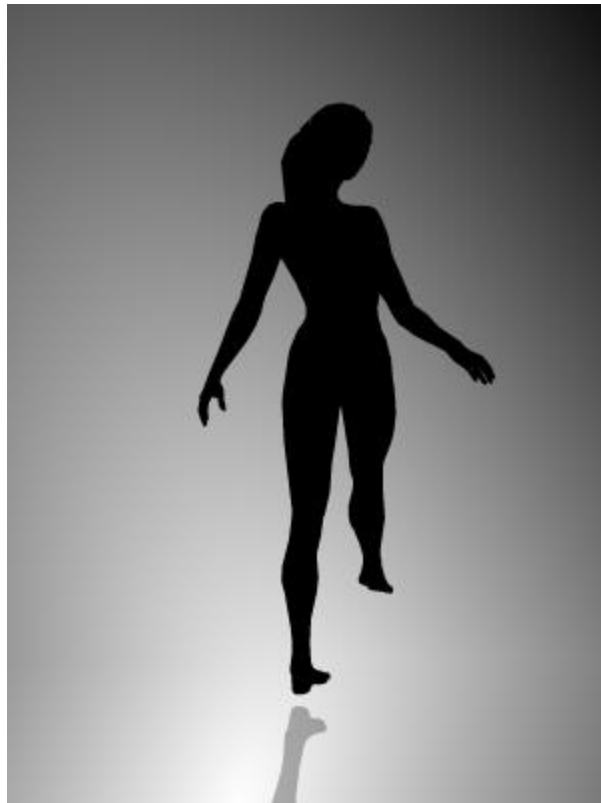

Classification

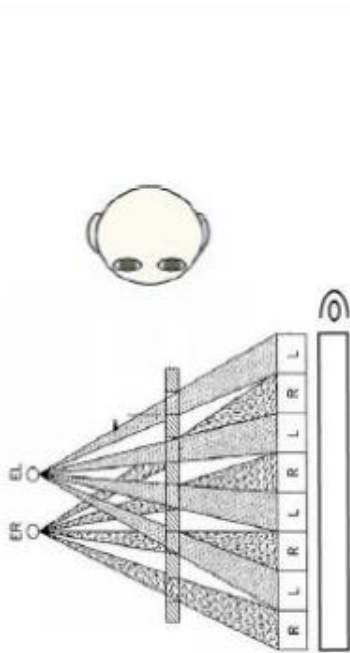

(a) Spatial-multiplexed

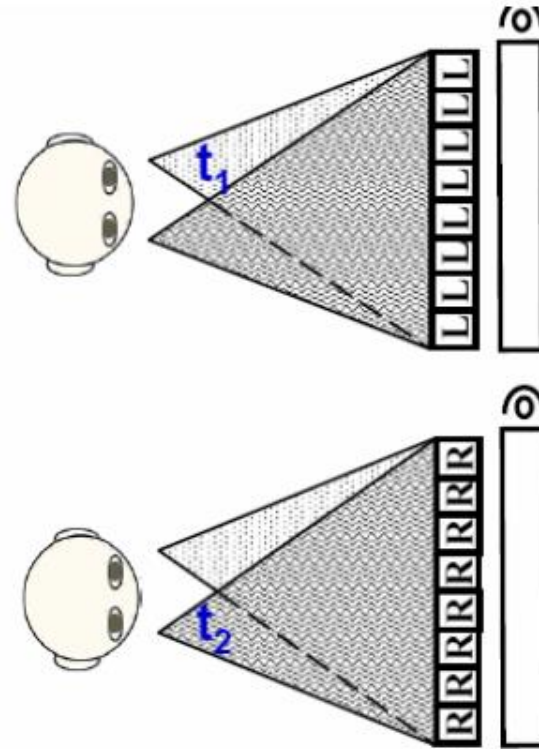

(b) Time-multiplexed

Perspective Projections

$$\frac{x}{z+d} = \frac{x_s}{d}$$

$$x_s = \frac{x}{1 + \frac{z}{d}}$$

$$y_s = \frac{y}{1 + \frac{z}{d}}$$

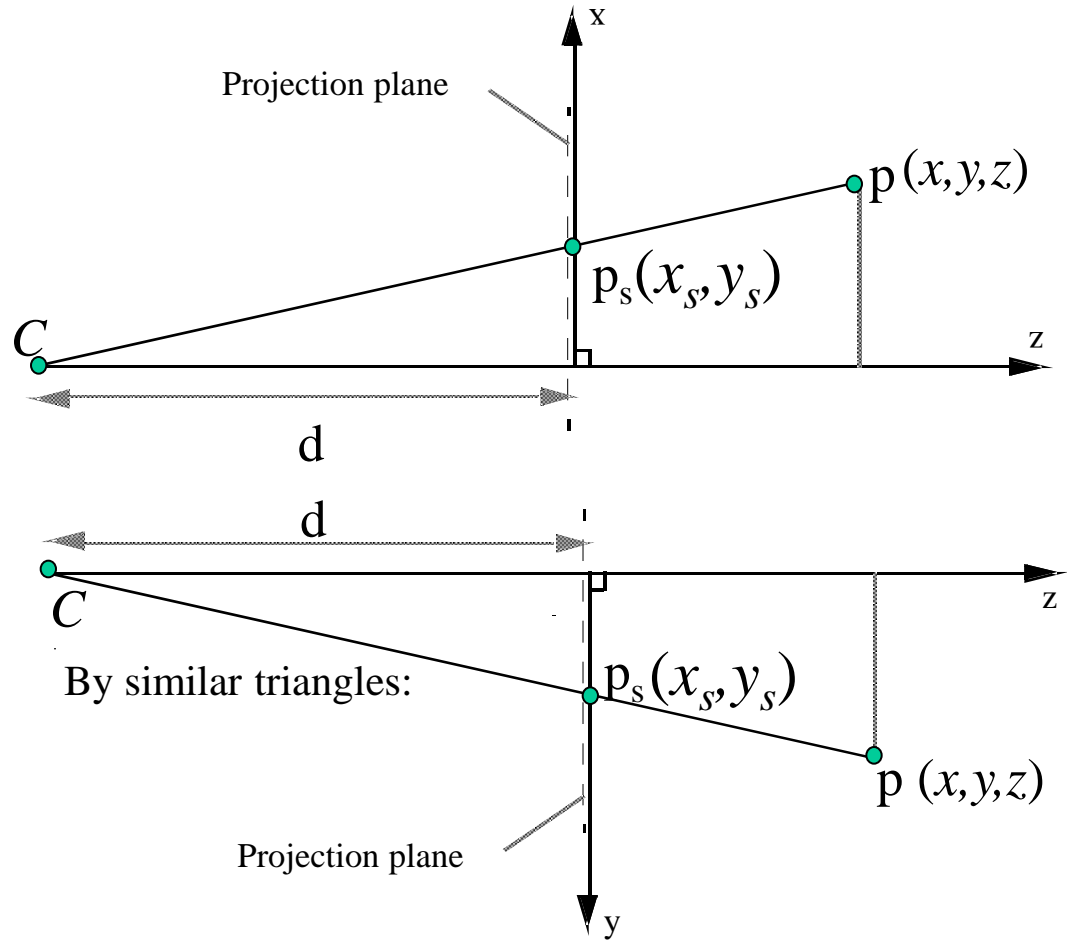

By similar triangles:

Distortion Solutions

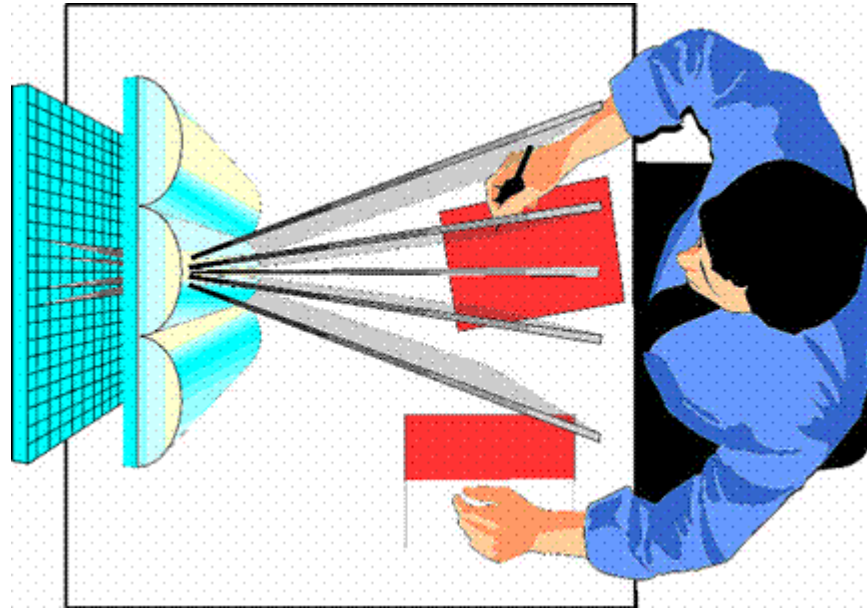

Increasing number of views (providing motion parallax)

Forming Viewing Zone

$$W_S = \frac{dV_w}{V_d}, \quad W_B = p - \frac{d}{V_d}(p + V_w)$$

$$W_S + W_B = p\left(1 - \frac{d}{V_d}\right)$$

$$d = \frac{pV_d}{(V_w + p)}, \quad W_S = \frac{pV_w}{V_w + p}$$

$$W_{SubS} = \frac{W_S}{K}$$

$$f = \frac{pV_d}{(V_w - p)}$$

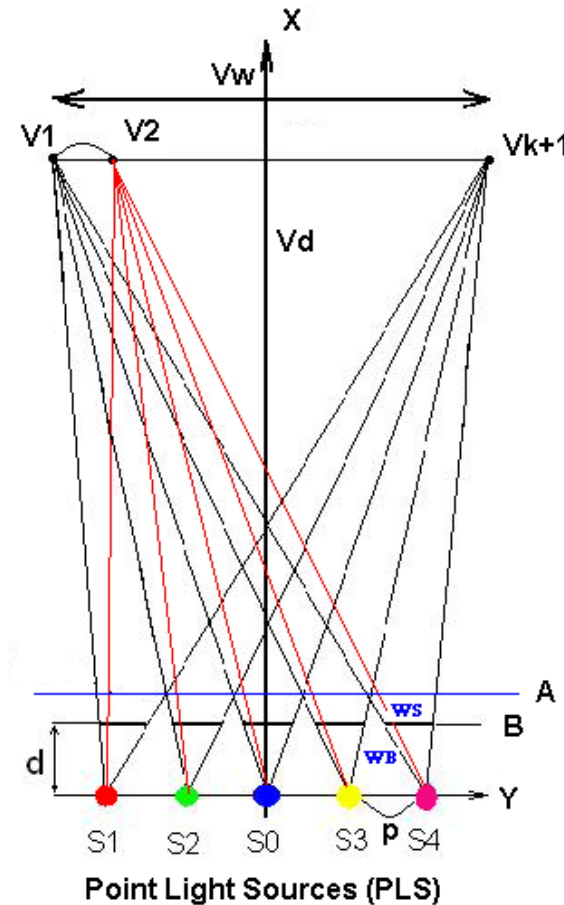

Obtainable Image Depth with PLS

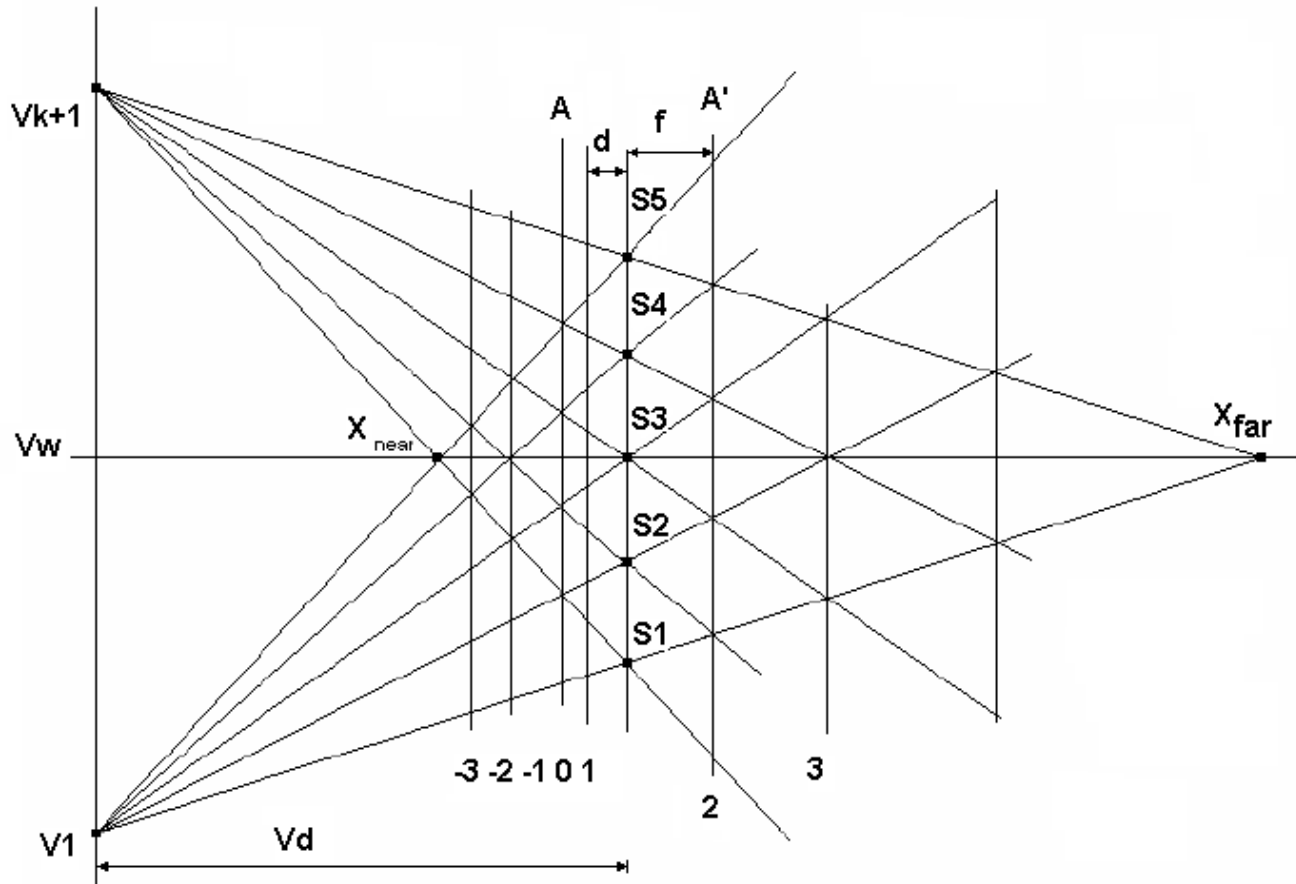

Parallax Barrier

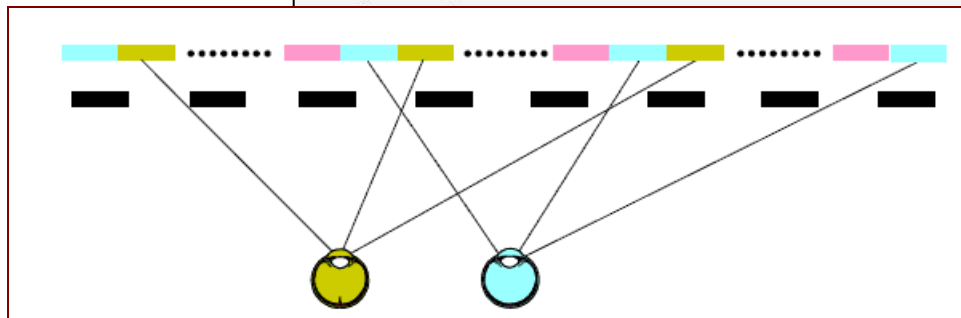
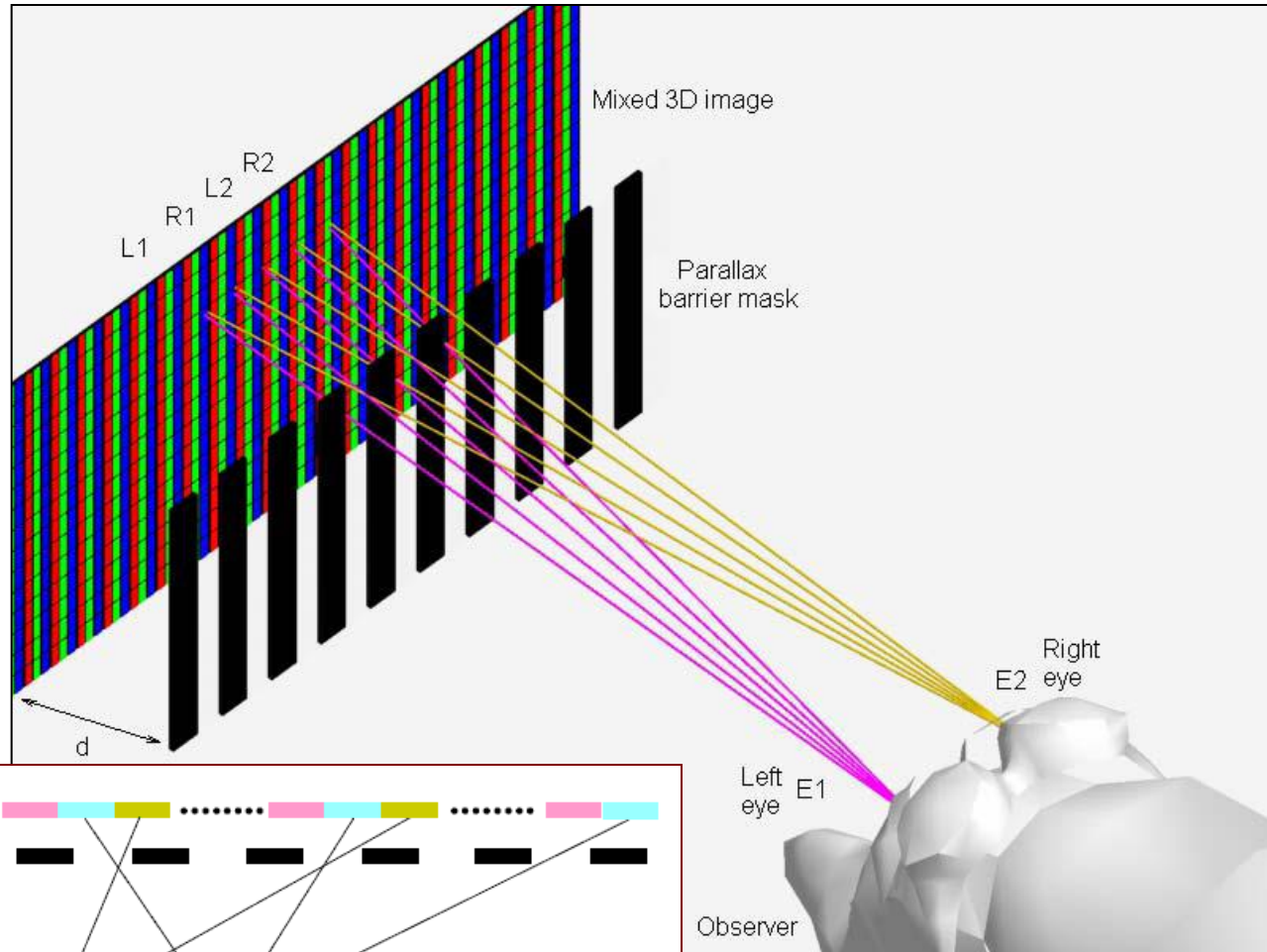

Lenticular

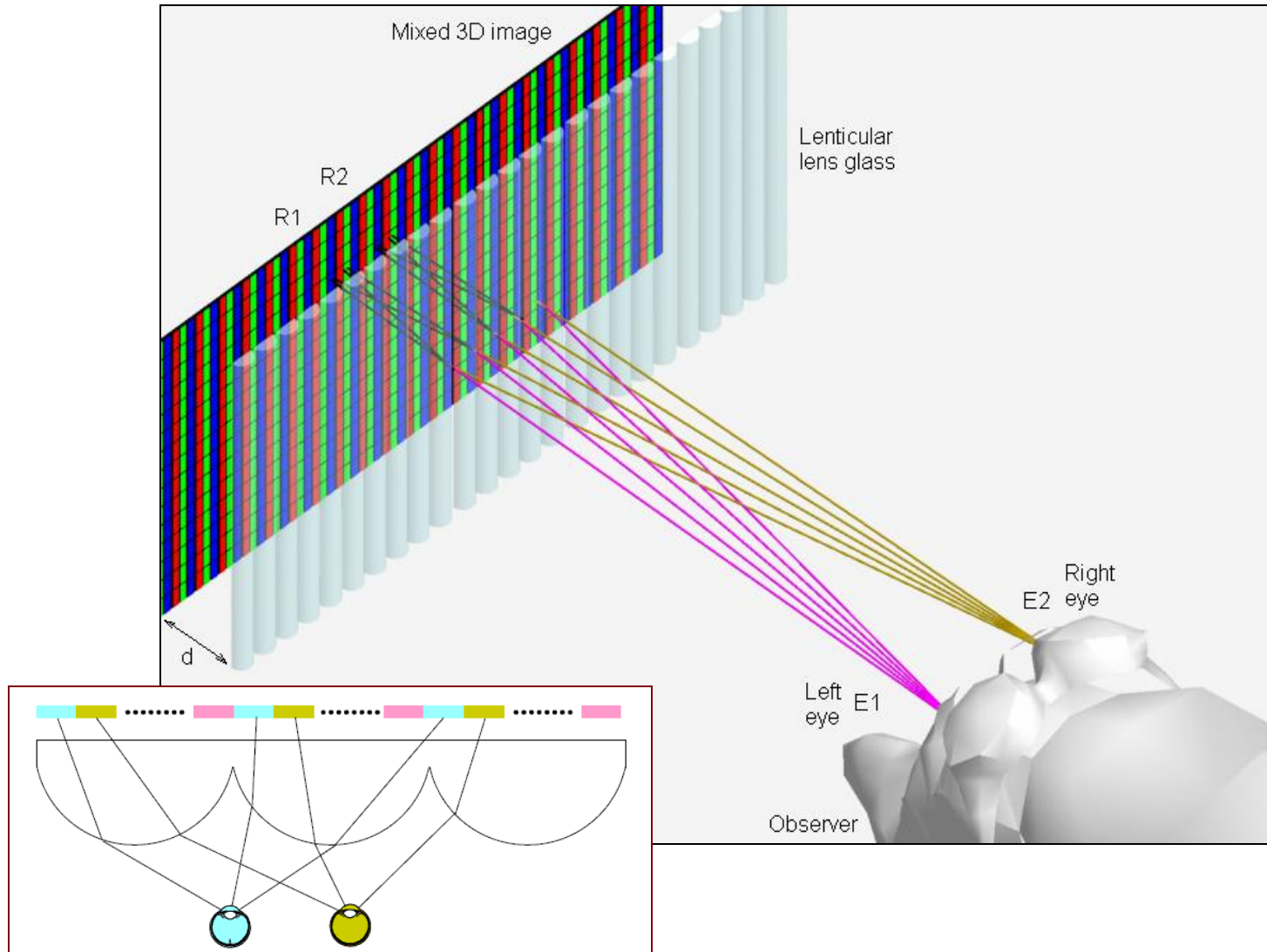

Distortion Solutions

- Using stereo camera having parallel configuration and stereo base equal to human eyes distance and preserving photographing and displaying condition the same

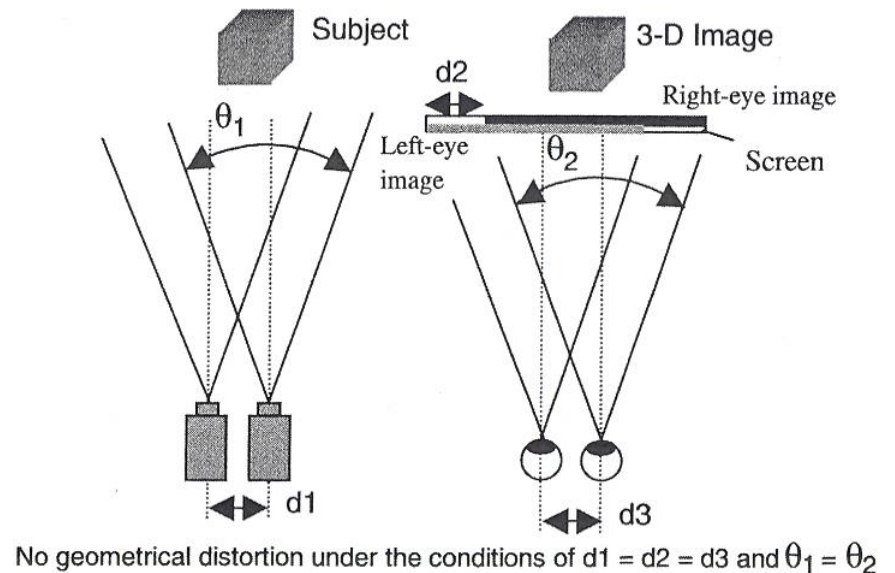

Ortho-stereoscopic
Conditions

Volumetric Display - Swept Volume



- 3D data set converted to 2D slices
- Flat screen rapidly rotates to sweep out a 3D volume
- Projection screen invisible to the viewer

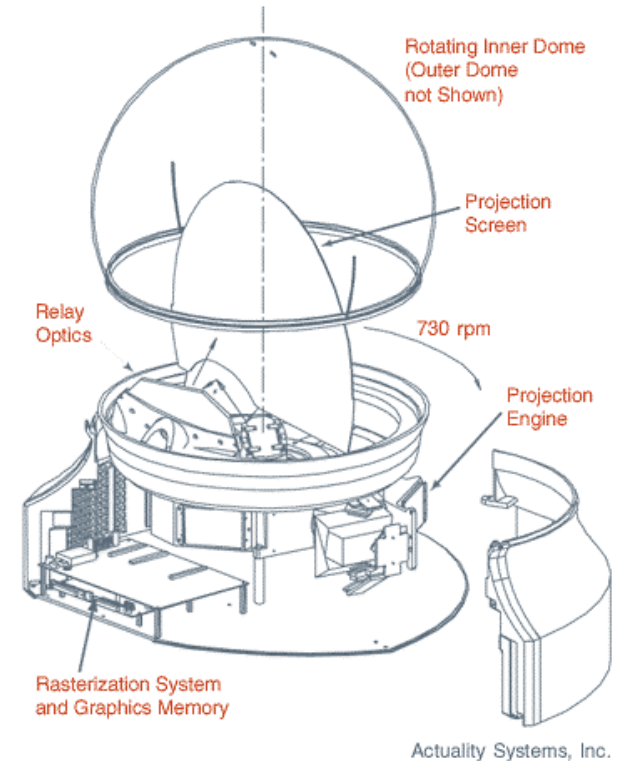

VOLUMETRIC DISPLAY

- Images created occupy a true volume

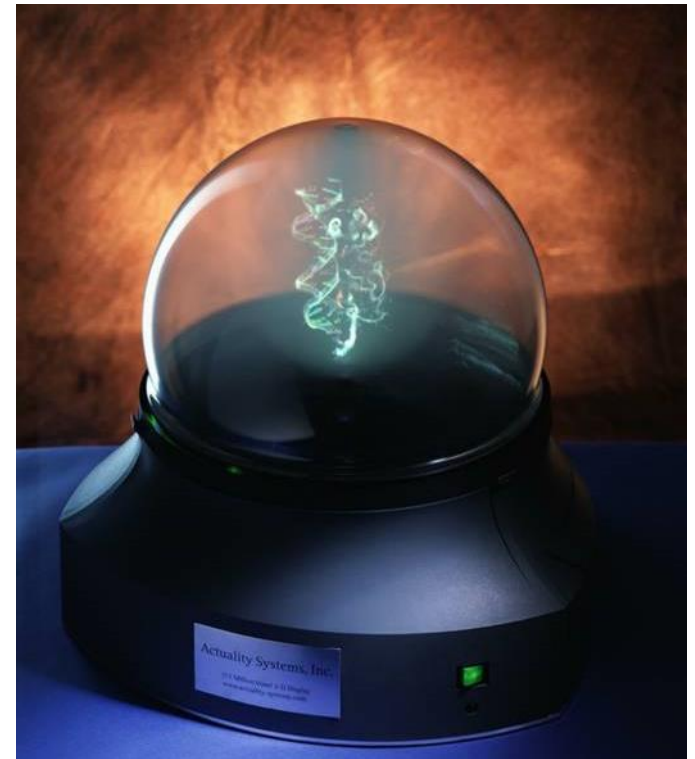
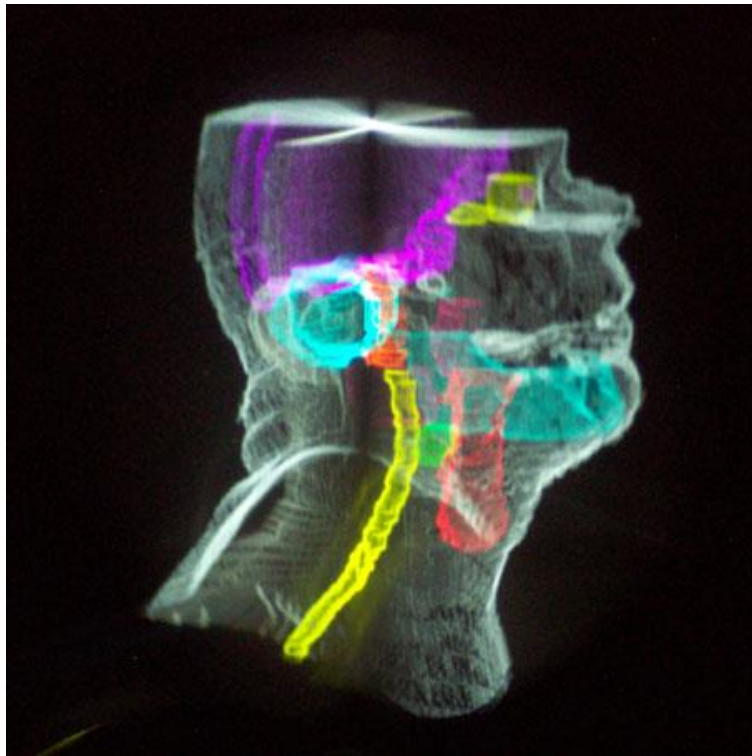

"Perspecta" - Actuality Systems

Volumetric Displays

- Perspecta
 - Bandwidth bottleneck
 - 1600x1200x32 bit colors at 85Hz requires 652MB/s
 - 3rd Dimension: 851GB/s

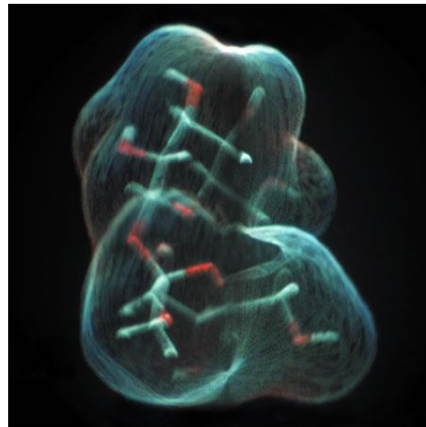

Volumetric Displays

- Plasma Flashpoints
 - National Institute of Advanced Industrial Science and Technology
 - Keio University
 - Burton Inc.

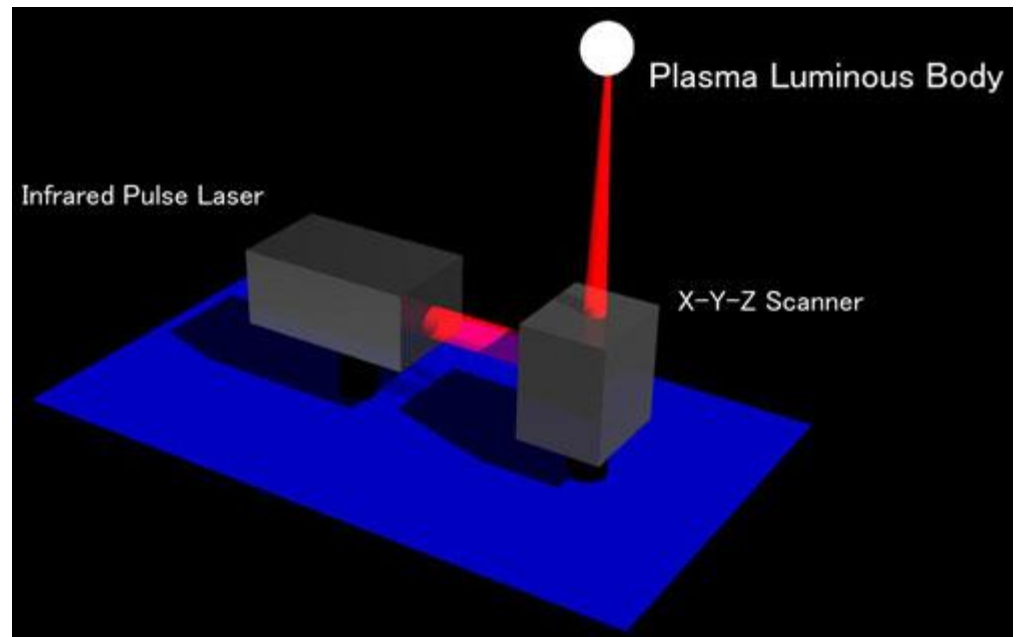
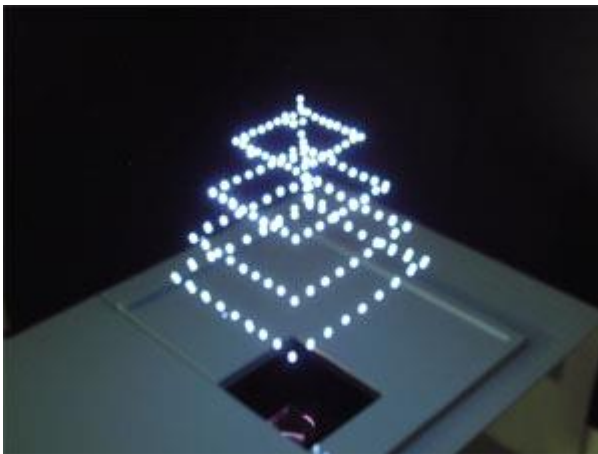

Volumetric Displays

- Plasma Flashpoints
 - Emission time on the order of 1 nano-second (1 pulse for each dot)
 - Human recognition due to after-image effect enables 100 dots/sec

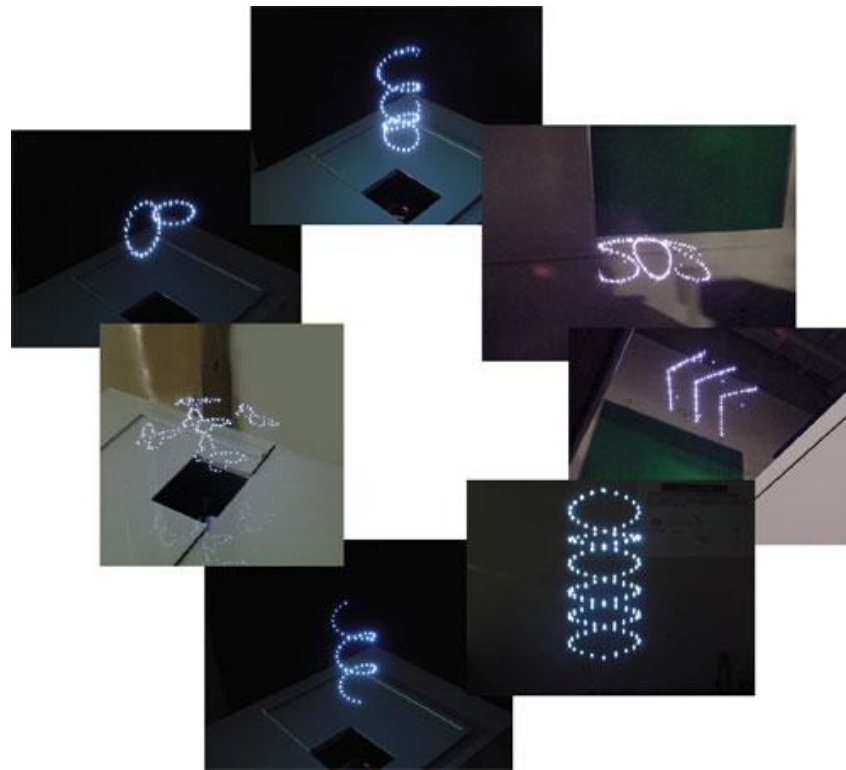

Comparison Between 3D- Methods

	Eye-Glasses	Multi-view	Holography	Volumetric	Laser-Beam	Psychological
Natural Depth	☹️ 😐	😊 😊	😊 😊	😊	☹️ 😐	☹️
Viewing Comfort	☹️	😊 😊	😊 😊	😊	😊	☹️
Group Viewing	😊	😊 😊	😊	😊	😊	😊
Compatibility: 2D/3D	😊	😊	☹️ 😐	😊	☹️	😊
No Degrade Picture	😊	😊	😊	😊	☹️	😊
Min Modification of Video Standard	😊	😊	☹️	😊	☹️ 😐	😊
Moderate Price	😊	😊	☹️	😊	☹️ 😐	☹️
😊 Possible 😐 Some Cases Possible ☹️ Impossible						

LIGHT AND BIOENGINEERING



Light Tissue Interactions

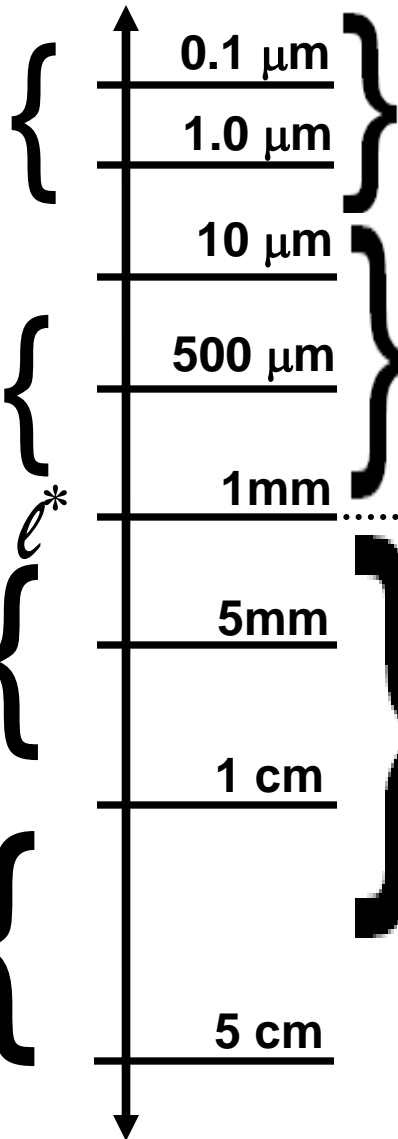
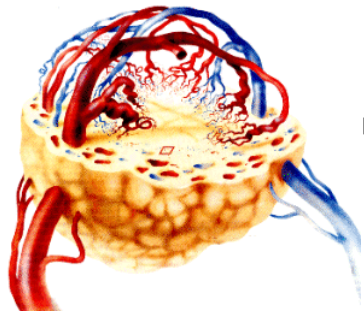
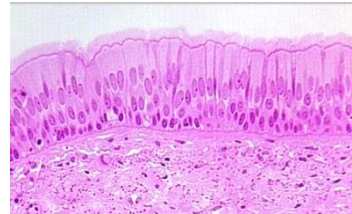
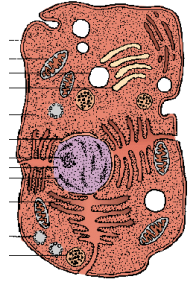

Molecules
Assemblies
Sub-cellular Structures
Cell Size/Shape/Density
Extra-Cellular Matrix

Scattering
($\ell_{sc} \sim 20 \mu\text{m}$)

Coherent

Diffuse

Bulk Properties:
Angiogenesis
Perfusion
Edema
Hypoxia
Necrosis

Scattering
&
Absorption
($\ell_{abs} \sim 10 \text{ cm}$)

Contrast enhancement techniques

- **Bright field (amplitude)**
- **Phase**
- **Dark field**
- **DIC (Nomarski)**
- **Polarization**
- **Fluorescence**
- **Reflectance**

Phase Methods

Confocal principle

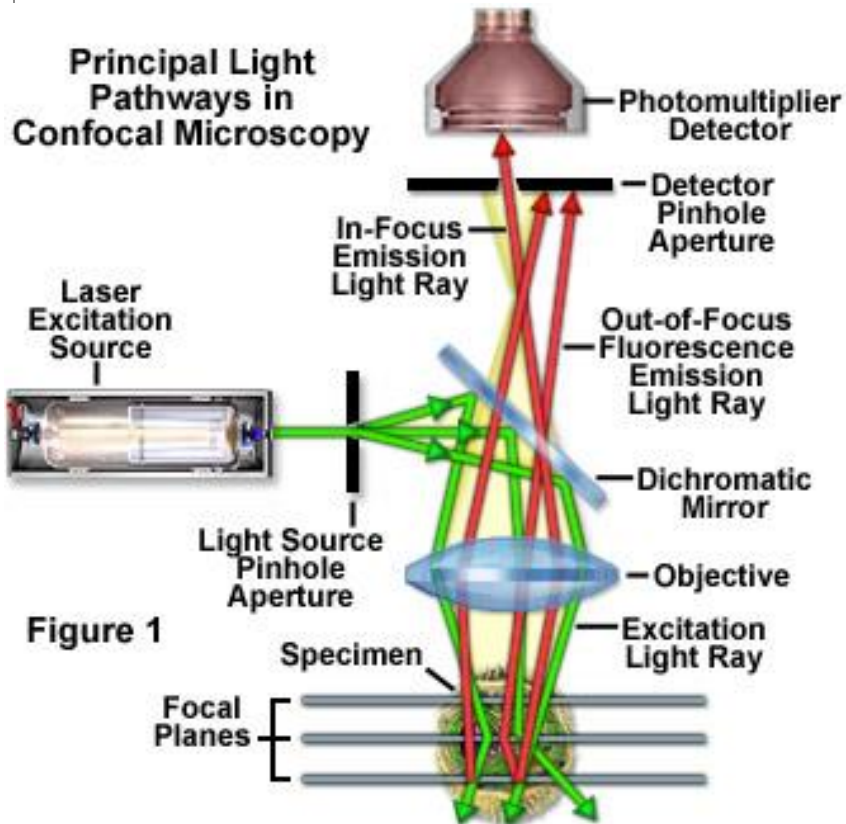

Figure 1

Wide-field
Confocal

Confocal and Widefield Fluorescence Microscopy

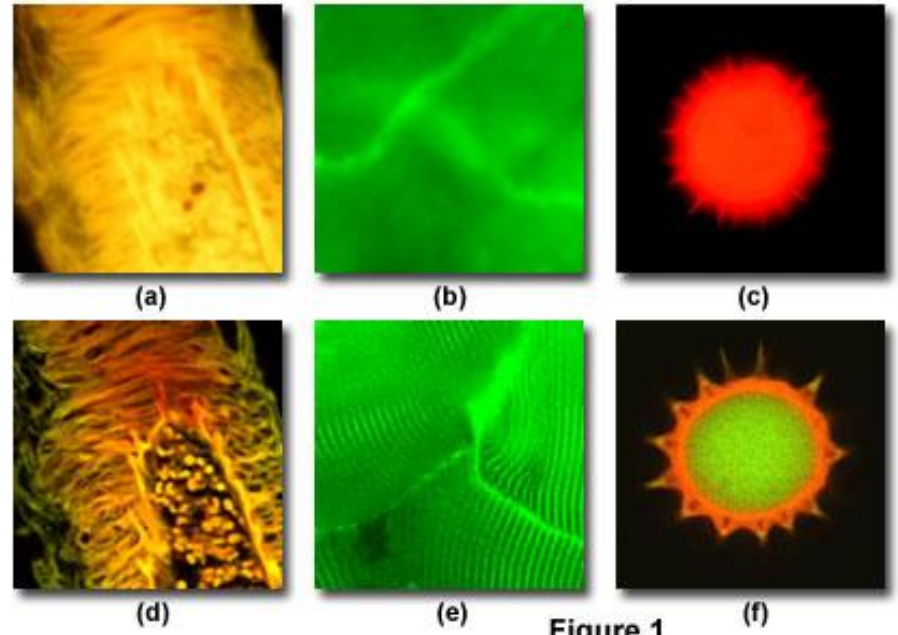

Figure 1

Widefield versus Confocal Point Scanning of Specimens



Figure 4

Same NA

NIR Optical Spectroscopy

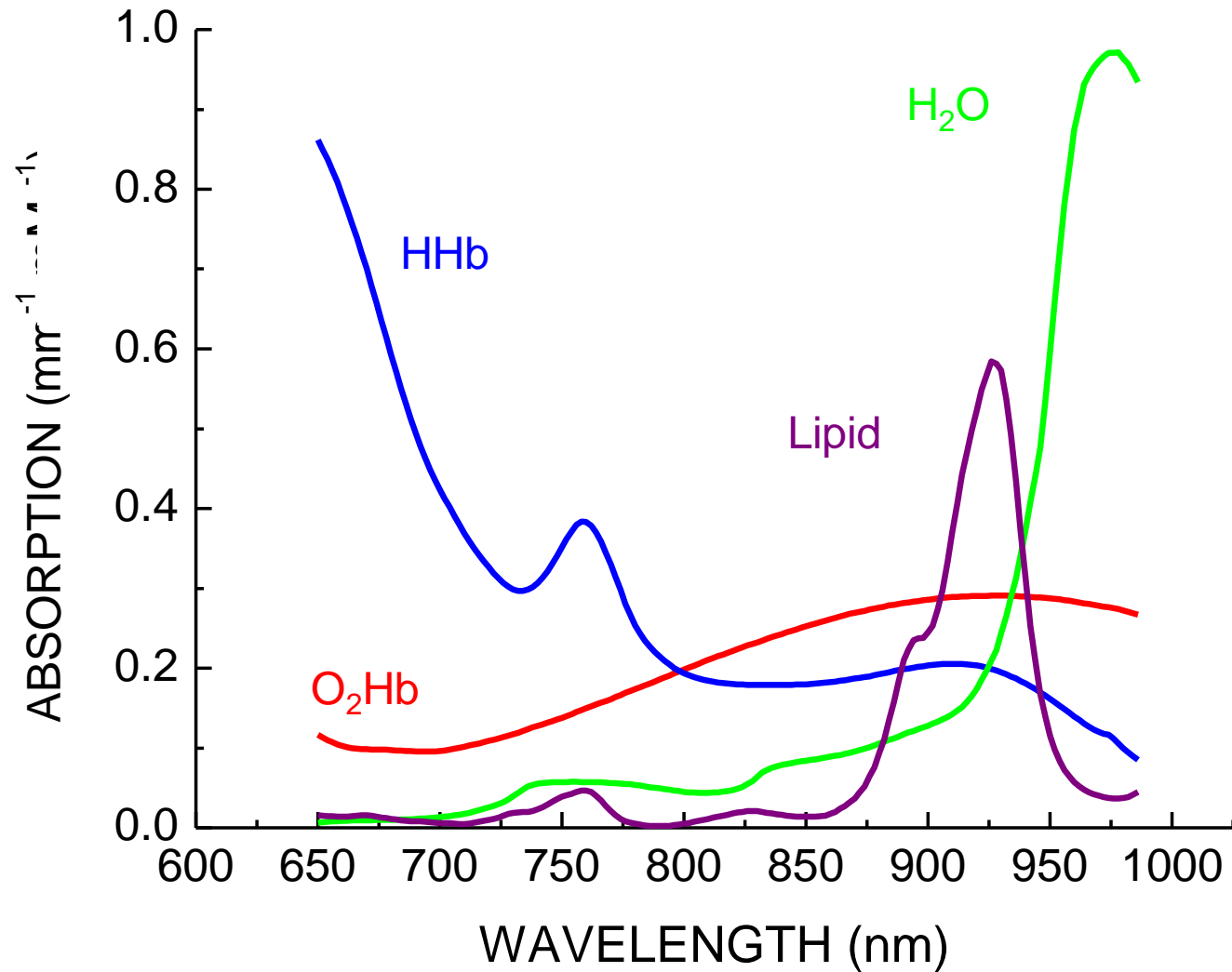

Other Applications



近代 光機電機 機動舞台技術

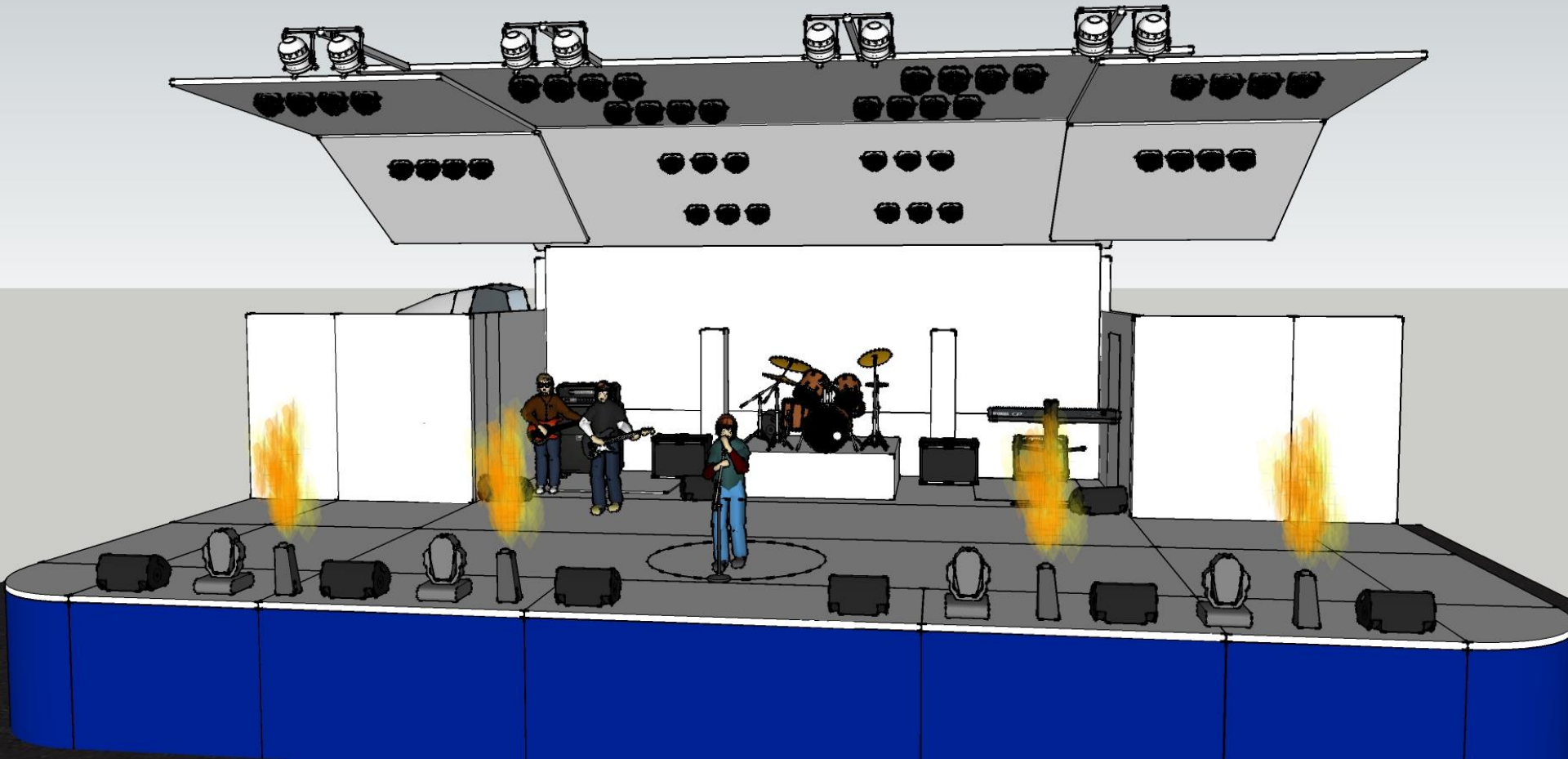



演員不怕舞台小 只怕無法感動觀眾