

**National Changhua University of Education**

**2013**

**光機電創意設計**

**OptoElectroMechatronic Device  
Creative Design**

**工程與生活**

**國立彰化師範大學  
機電工程學系 王可文 編**



**Prepared by Kerwin Wang  
Department of Mechatronics Engineering**

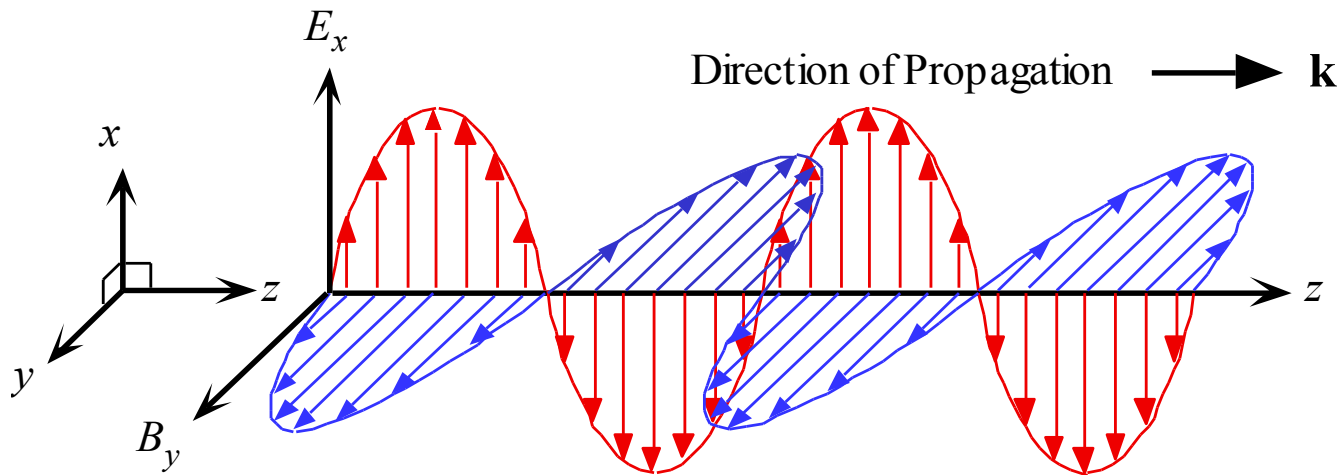
# Optoelectronics and Photonics

近代光電發明原理

## 平面電磁波

- 最簡單的行進波為正弦波；對沿方向傳播的波，其數學一般式表示為

$$E_x = E_0 \cos(\omega t - kz + \phi_0) \quad (1)$$

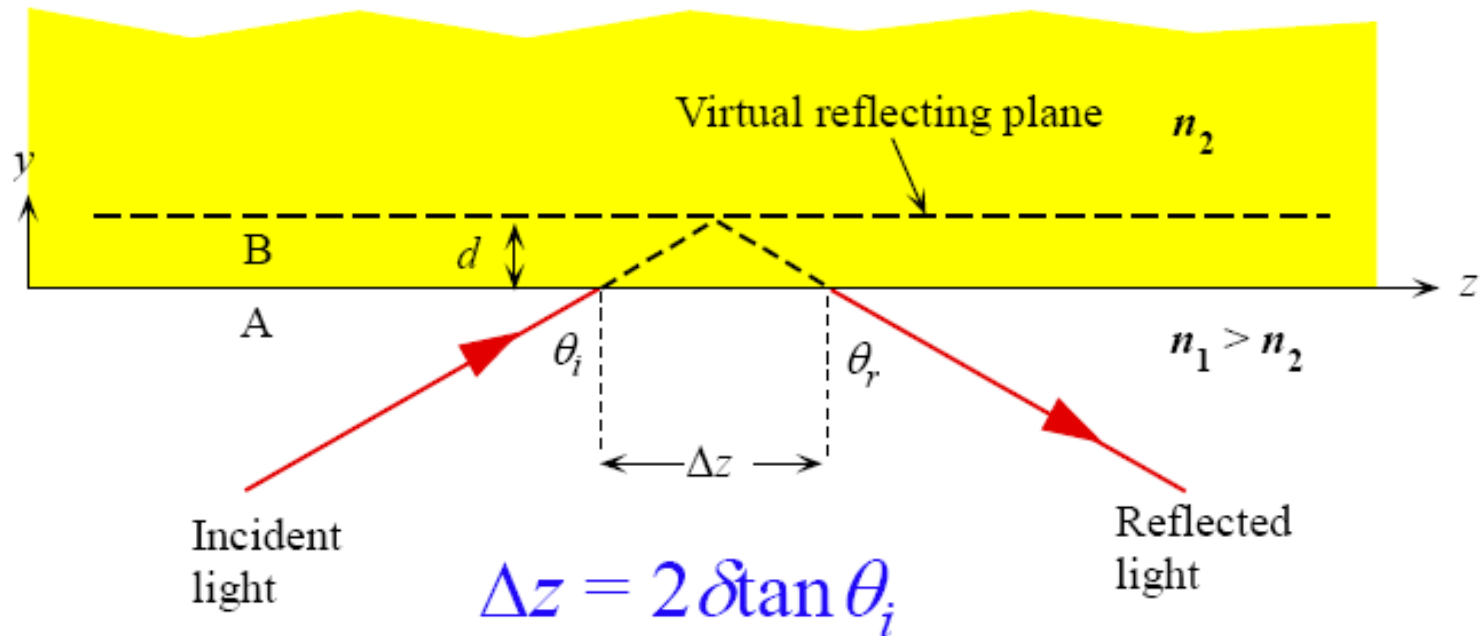


An electromagnetic wave is a travelling wave which has time varying electric and magnetic fields which are perpendicular to each other and the direction of propagation,  $z$ .

一個電磁波為一個具有時變電場及磁場的行進波，且二者相互垂直並垂直傳播方向。

# 古斯-亨琴移動與光學隧道作用

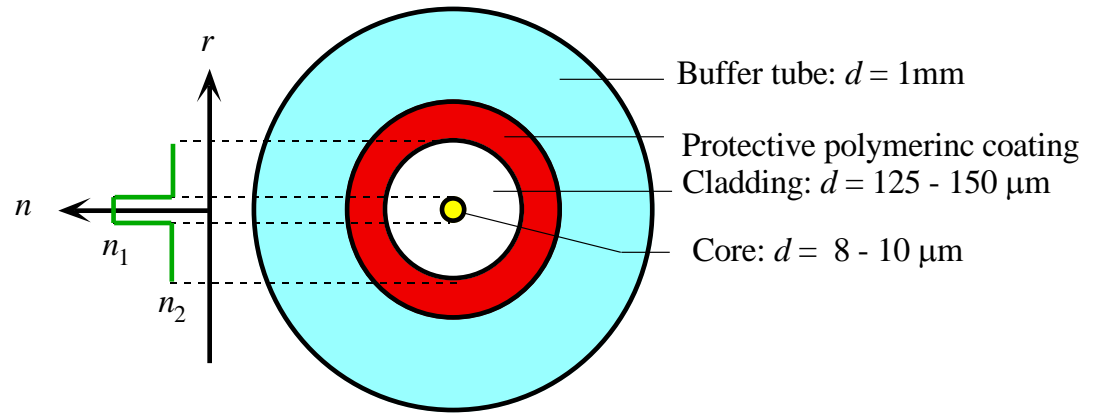
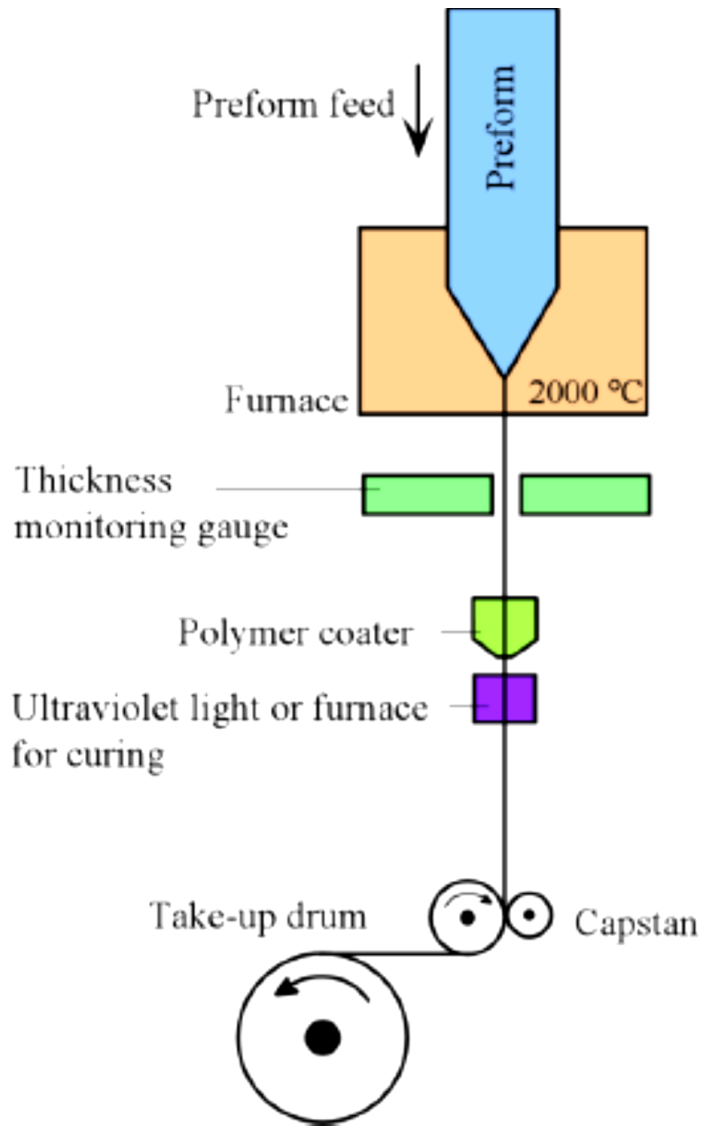
## Goos-Hänchen Shift



內部全反射的反射光束顯示在界面上已被橫向位移一個量 $\Delta z$ 。

Shift &  
Depth

# 光纖製造

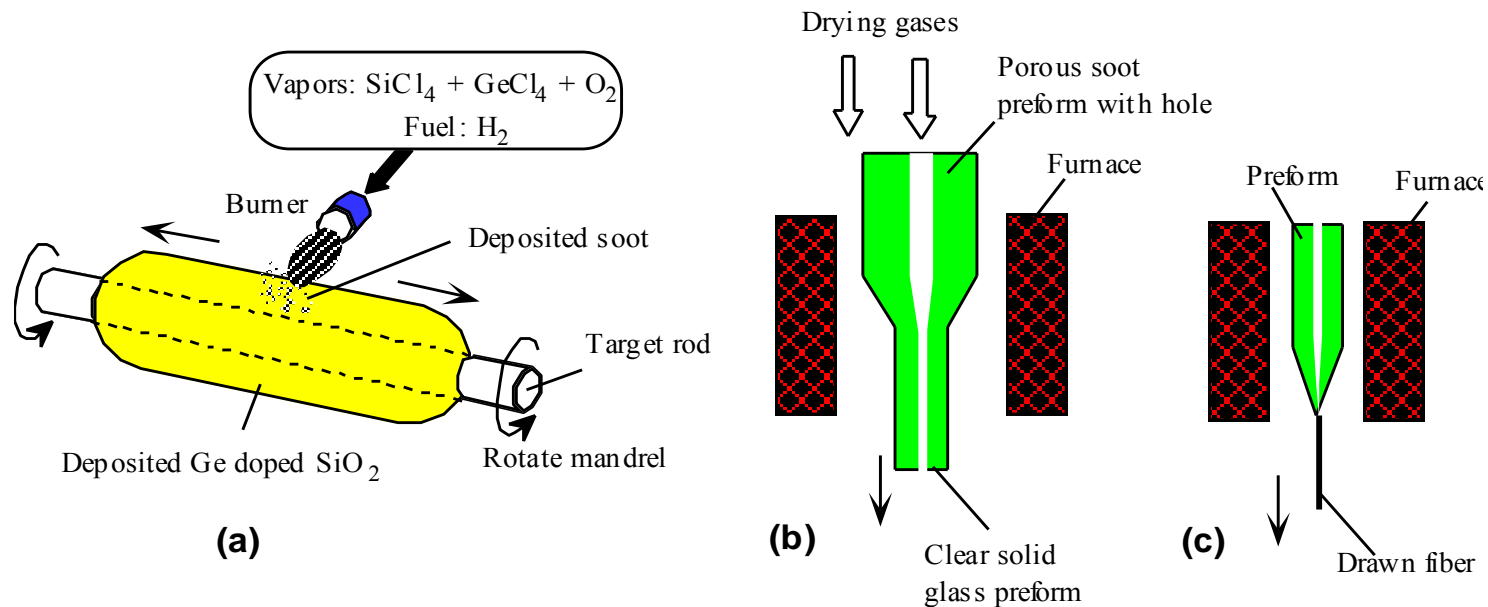


The cross section of a typical single-mode fiber with a tight buffer tube. ( $d$  = diameter)

?1999 S.O. Kasap, *Optoelectronics* (Prentice Hall)

圖 → 具有一個堅固緩衝管的典型單模光纖的橫切面。(d=直徑)。

圖 → 光纖抽絲塔之圖解說明。



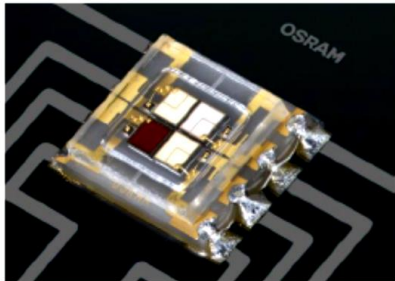
Schematic illustration of OVD and the preform preparation for fiber drawing. (a) Reaction of gases in the burner flame produces glass soot that deposits on to the outside surface of the mandrel. (b) The mandrel is removed and the hollow porous soot preform is consolidated; the soot particles are sintered, fused, together to form a clear glass rod. (c) The consolidated glass rod is used as a preform in fiber drawing.

©1999 S.O. Kasap, *Optoelectronics* (Prentice Hall)

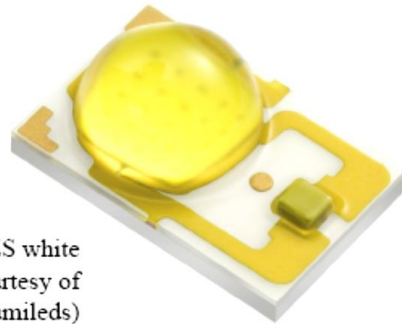
圖 → OVD以及光纖抽絲所需預形體準備的圖解說明。(a) 燃燒器火焰中的氣體反應產生玻璃煙灰並沉積在心軸的外表面；(b) 心軸移走且中空多孔的煙灰預形體被固化，即煙灰顆粒昇華、熔化在一起而形成一個透明的玻璃棒；(c) 所固化的玻璃棒當作光纖抽絲的預形體。

# 發光二極體

## Light Emitting Diodes



This multichip LED from Osram is used in microprojectors. It is based on thin film GaN technology. (Courtesy of Osram)



LUXEON Rebel ES white emitting LED (Courtesy of Philips Lumileds)



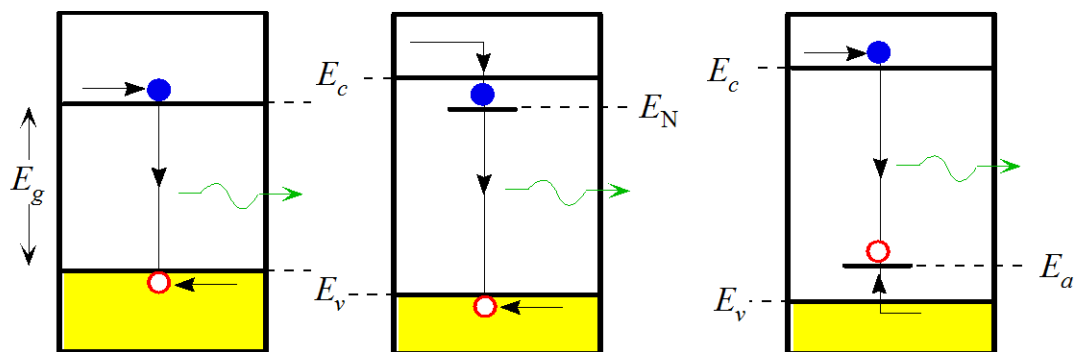
Snap LED emitting in the amber for automotive signaling applications. The lamp includes the driver under the LED (Courtesy of Philips Lumileds)

## Microprojector using LEDs





# LED材料



(a)  $\text{GaAs}_{1-y}\text{P}_y$   
 $y < 0.45$

(b) N doped GaP

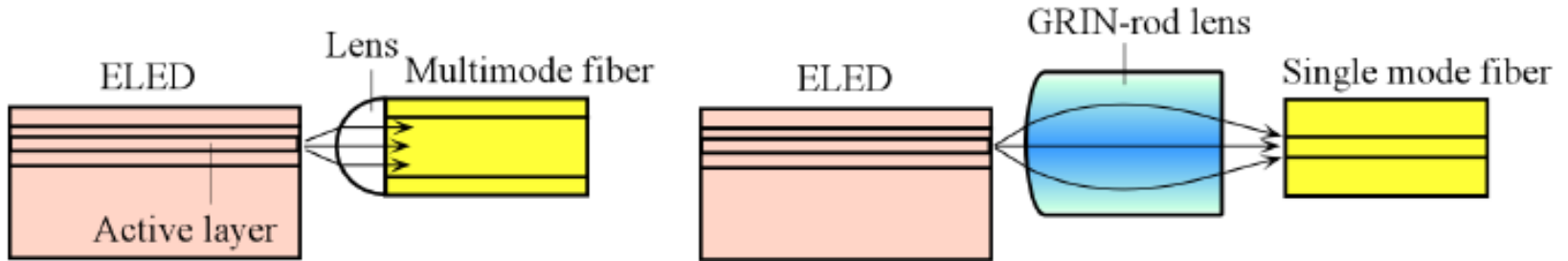
(c) Al doped SiC

(a) Photon emission in a direct bandgap semiconductor. (b). GaP is an indirect bandgap semiconductor. When doped with nitrogen there is an electron trap at  $E_N$ . Direct recombination between a trapped electron at  $E_N$  and a hole emits a photon. (c) In Al doped SiC, EHP recombination is through an acceptor level like  $E_a$ .

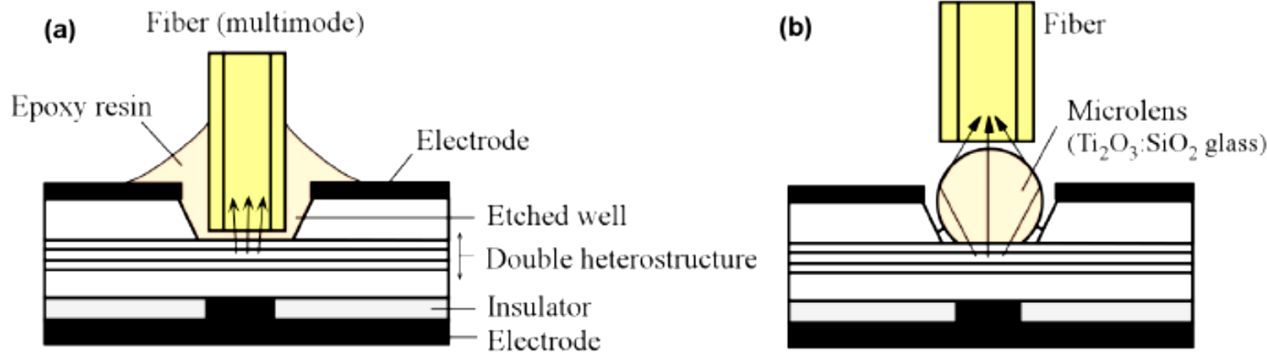
(a) 直接能隙半導體的光子發射，(b) GaP 是一間接能隙半導體，當摻入氮，將有一電子陷阱在  $E_N$ ，在  $E_N$  的陷入電子和電洞直接復合，並發射光子，(c) 在 Al 摻雜的 SiC，EHP 復合是經由受體階，比如  $E_a$ 。

# 光纖通訊用LED

邊緣發射 E LED

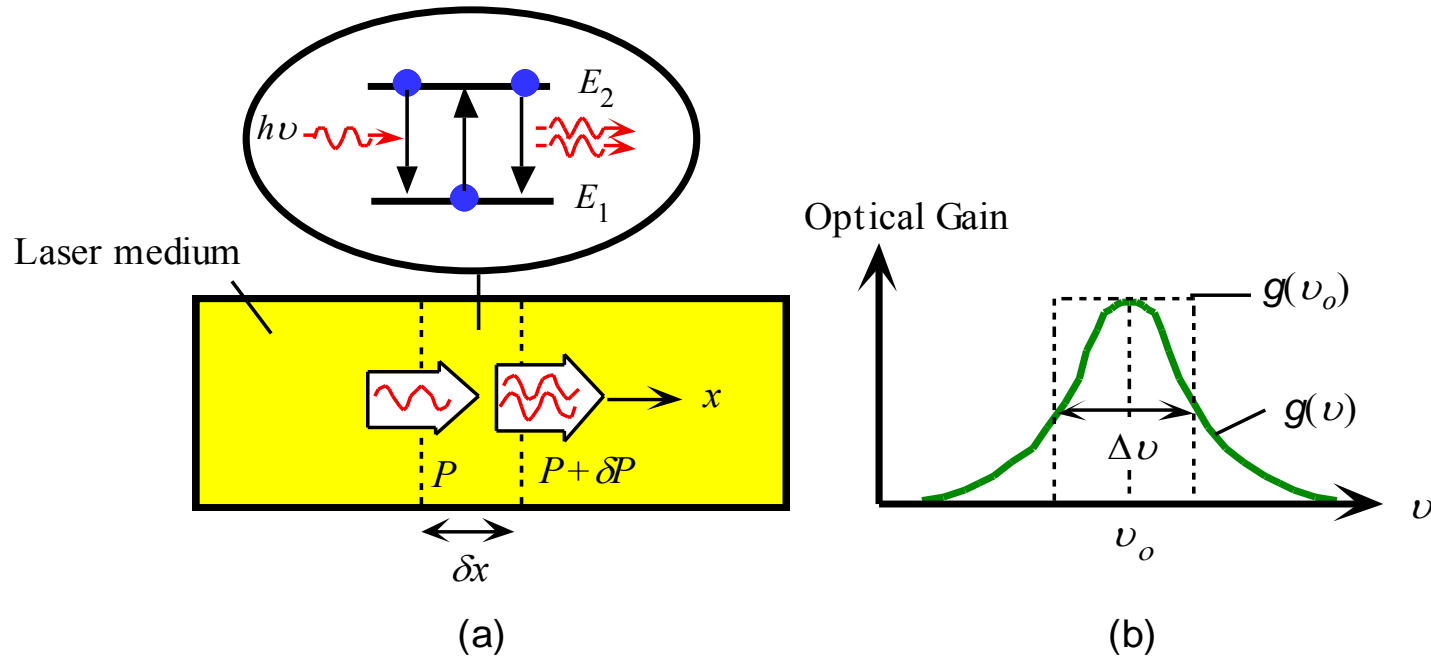


面發射 S LED



(a) 光由面發射LED耦合進入多模光纖，其中使用折射率匹配的環氧樹脂光纖被黏合於LED結構上，(b) 微透鏡將面發射LED的發散光聚焦並導入多模光纖中。

# 雷射共振條件

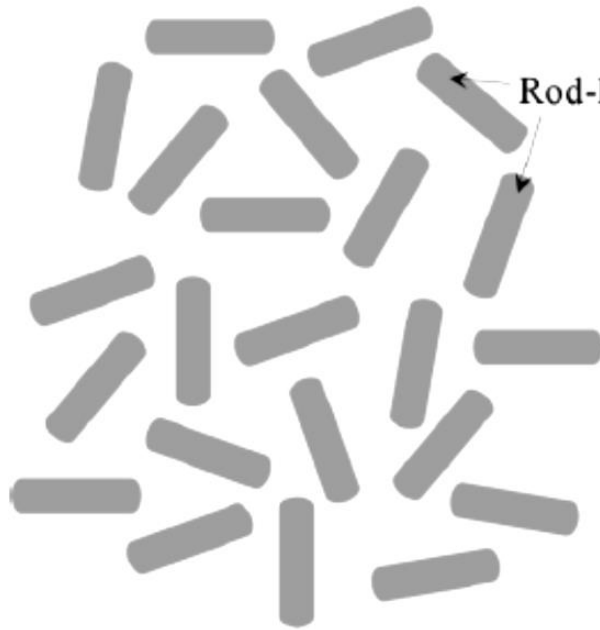


(a) A laser medium with an optical gain (b) The optical gain curve of the medium. The dashed line is the approximate derivation in the text.

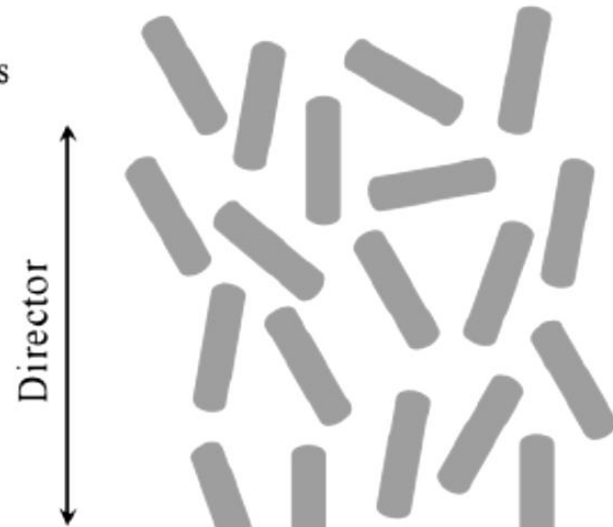
?1999 S.O. Kasap, *Optoelectronics* (Prentice Hall)

(a) 具有光增益的雷射介質 (b) 介質的光增益曲線。虛線是參考書中的近似推導。

# LCD (Liquid Crystal Display)



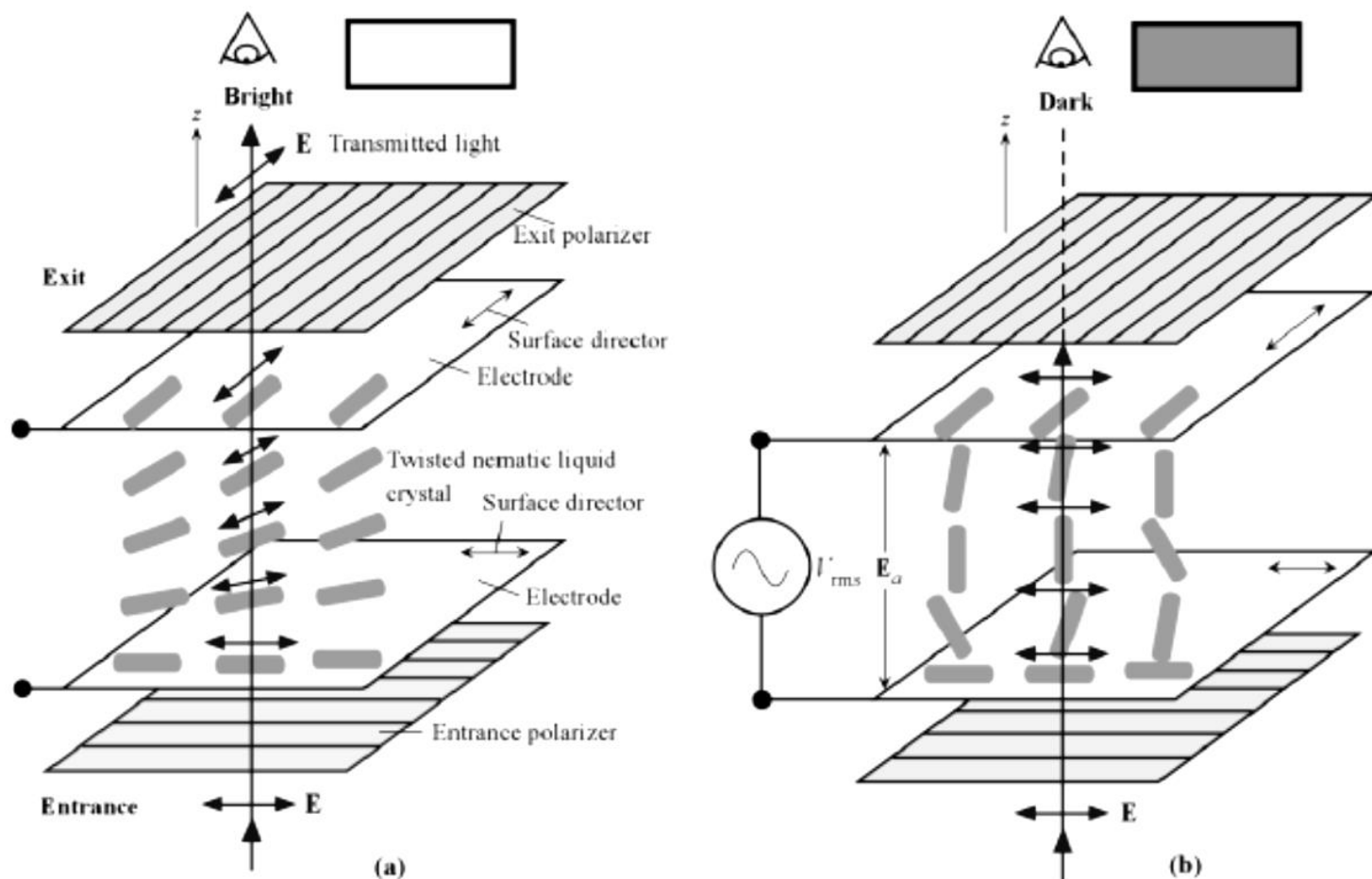
Random orientations



Nematic phase with a degree of orientational disorder

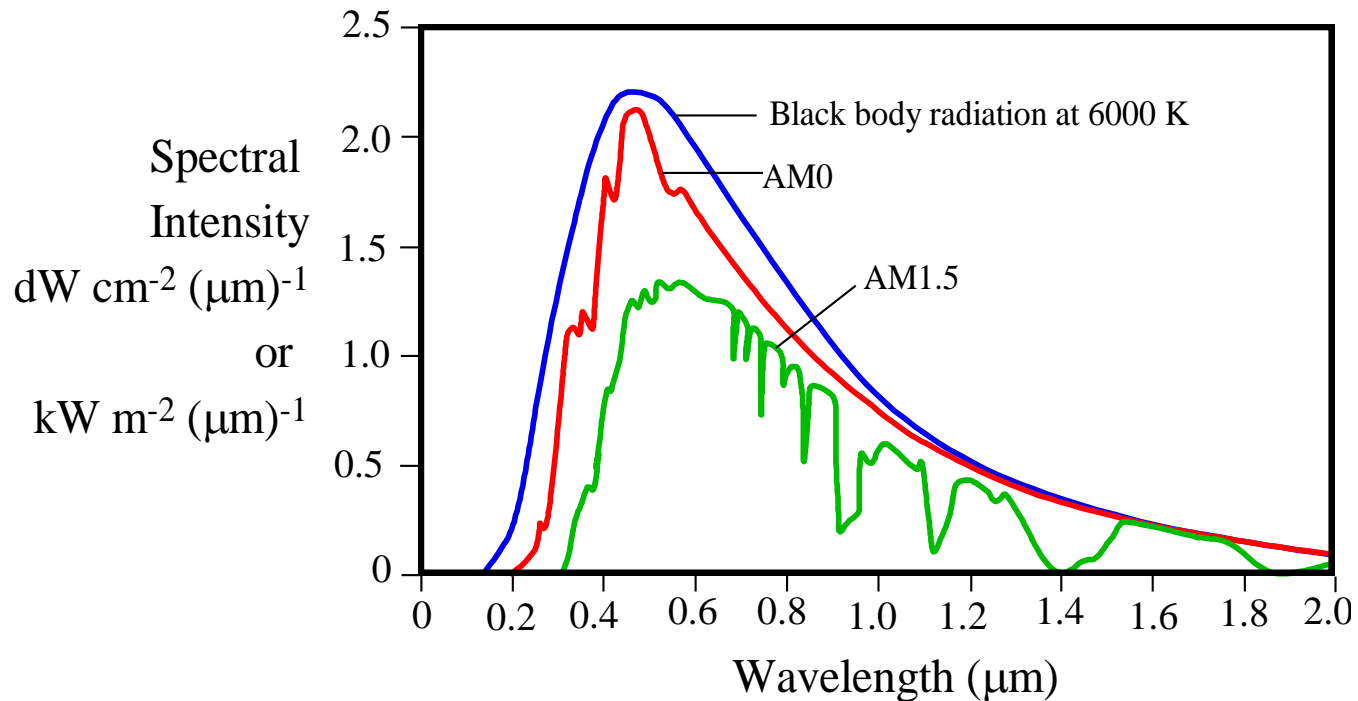


Photo by SK



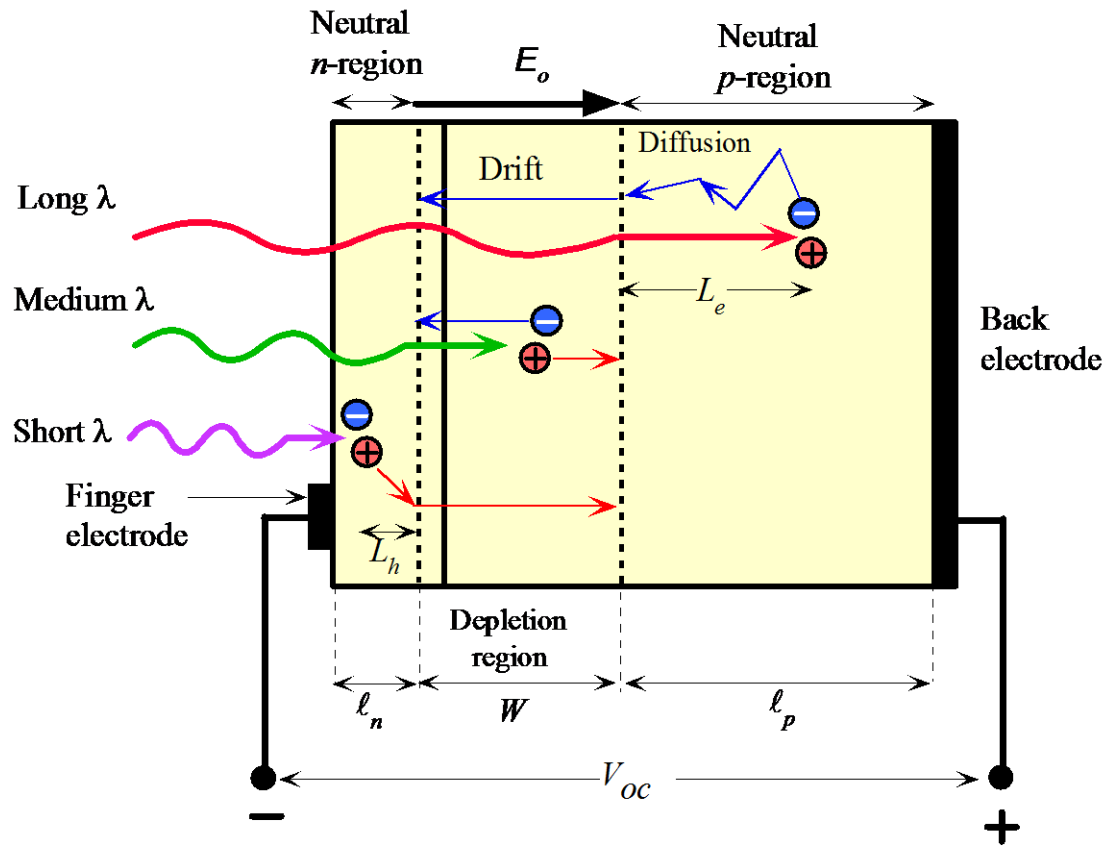
Transmission based LCD. (a) In the absence of a field, the liquid crystal has the twisted nematic phase and the light passing through it has its polarization rotated by  $90^\circ$ . The light is transmitted through both polarizers. The viewer sees a bright image. (b) When a voltage, and hence a field  $E_a$ , is applied, the molecules in the liquid crystal align with the field  $E_a$  and are unable to rotate the polarization of the light passing through it; light therefore cannot pass through the exit polarizer. The light is extinguished, and the viewer see dark image.

# 太陽能光譜



The spectrum of the solar energy represented as spectral intensity ( $I_\lambda$ ) vs wavelength above the earth's atmosphere (AM0 radiation) and at the earth's surface (AM1.5 radiation). Black body radiation at 6000 K is shown for comparison (After H.J. Möller, *Semiconductors for Solar Cells*, Artech House Press, Boston, 1993, p.10)

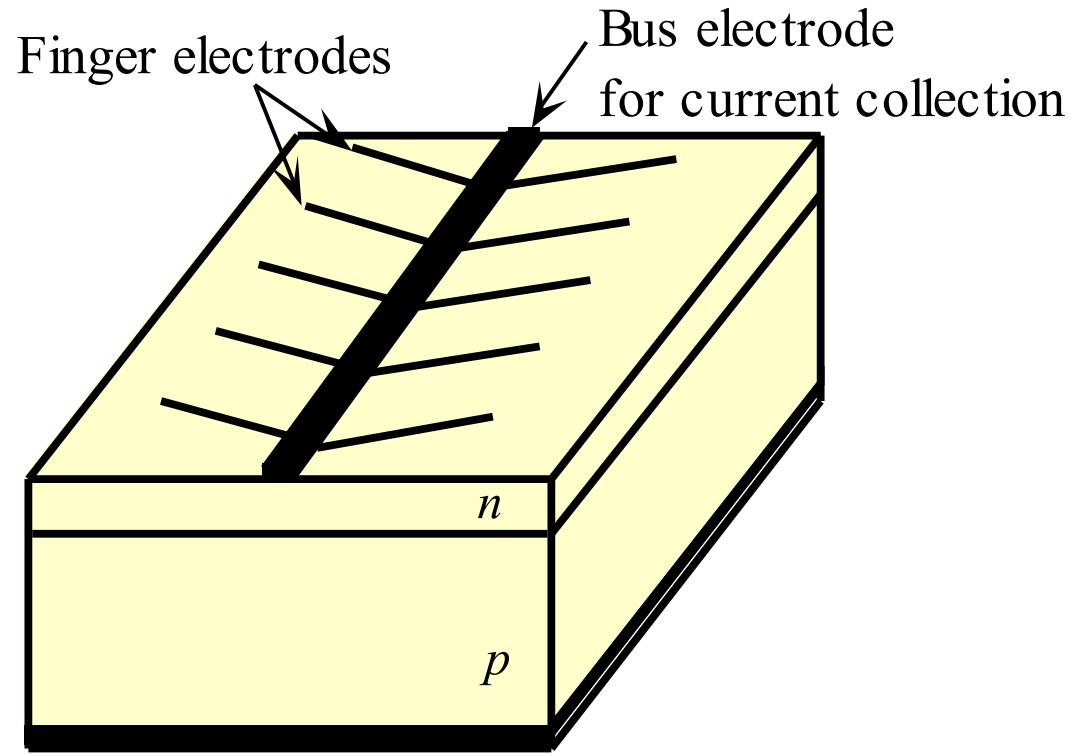
From S.O. Kasap, *Optoelectronics and Photonics: Principles and Practices* (Prentice Hall)



The principle of operation of the solar cell (exaggerated features to highlight principles)

©1999 S.O. Kasap, *Optoelectronics* (Prentice Hall)

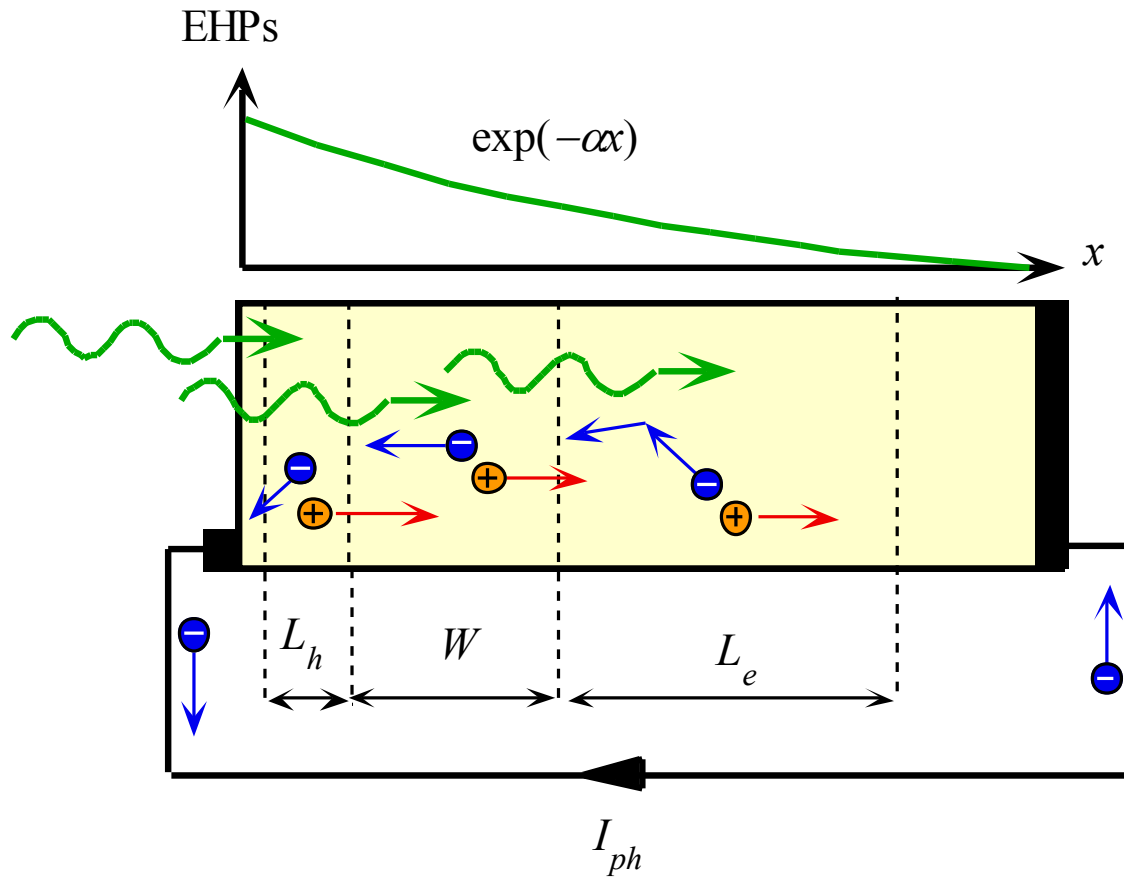
太陽能電池的工作原理（跨大的圖形以放大工作原理）。



Finger electrodes on the surface of a solar cell reduce the series resistance

?1999 S.O. Kasap, *Optoelectronics* (Prentice Hall)

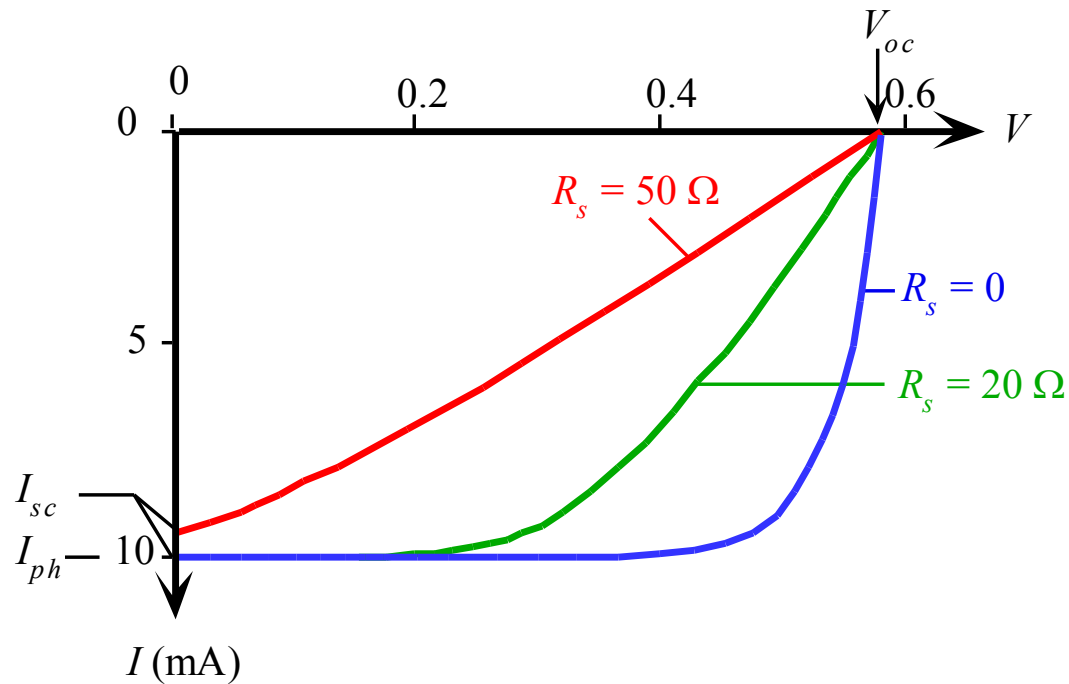
太陽能電池表面上的文叉指型電極可降低串聯電阻。



Photogenerated carriers within the volume  $L_h + W + L_e$  give rise to a photocurrent  $I_{ph}$ . The variation in the photogenerated EHP concentration with distance is also shown where  $\alpha$  is the absorption coefficient at the wavelength of interest.

?1999 S.O. Kasap, *Optoelectronics* (Prentice Hall)

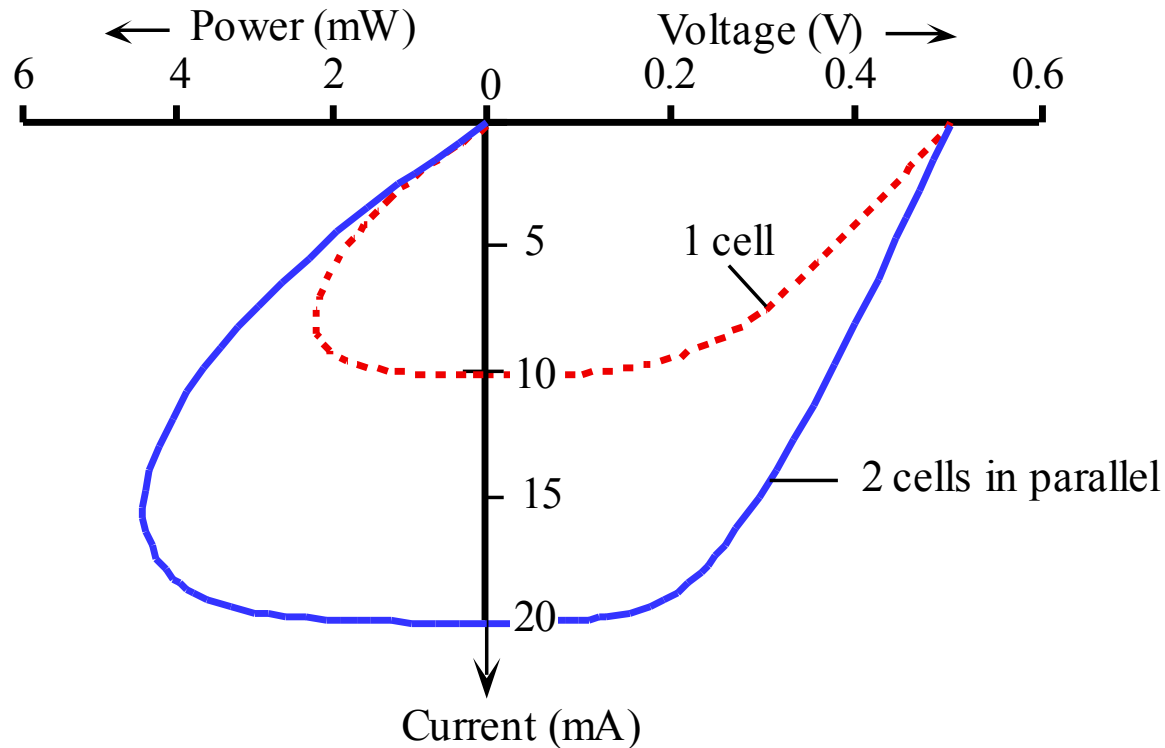
在  $L_n + W + L_e$  體積內光產生的載子造成光電流  $I_{ph}$ 。光產生電子-電洞對濃度隨著距離的改變也圖示在這裡， $\alpha$  是感興趣波長的吸收係數。



The series resistance broadens the  $I$ - $V$  curve and reduces the maximum available power and hence the overall efficiency of the solar cell. The example is a Si solar cell with  $n \approx 1.5$  and  $I_o \approx 3 \times 10^{-6}$  mA. Illumination is such that the photocurrent  $I_{ph} = 10$  mA.

?1999 S.O. Kasap, *Optoelectronics* (Prentice Hall)

串聯電阻會使I-V曲綫變寬，並降低最大可能功率，因此使得太陽能電池的整體效率降低。圖中的例子是矽製太陽能電池，且  $n \approx 1.5$   $I_o \approx 3 \times 10^{-6}$  mA 光電流  $I_{ph} \approx 10$  mA

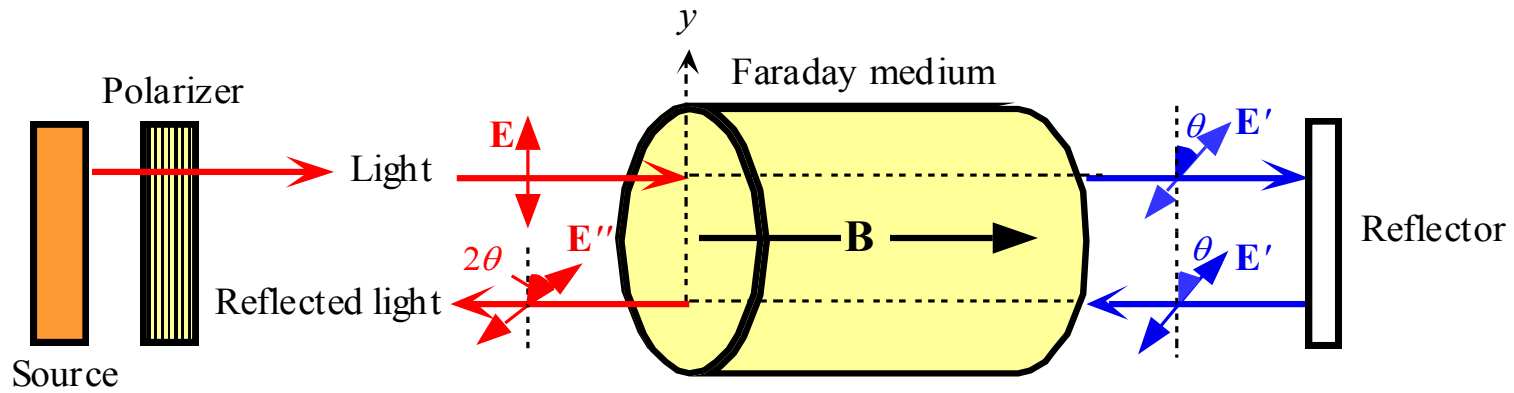


Current vs. Voltage and Power vs. Current characteristics of one cell and two cells in parallel. The two parallel devices have  $R_s/2$  and  $2I_{ph}$ .

?1999 S.O. Kasap, *Optoelectronics* (Prentice Hall)

圖6.12 一個電池和兩個並聯電池的電流對電壓與功率對電流的特性。兩個並聯元件有  $R_s/2$  和  $2I_{ph}$ 。

# 磁-光效應



The sense of rotation of the optical field  $E$  depends only on the direction of the magnetic field for a given medium (given Verdet constant). If light is reflected back into the Faraday medium, the field rotates a further  $\theta$  in the same sense to come out as  $E''$  with a  $2\theta$  rotation with respect to  $E$ .

光場  $E$  的旋轉與所給材料的磁場方向有關（給定伯地特常數）。假如光被反射回去進入法拉第介質，電場會變成  $E''$  以相同的方向旋轉  $2\theta$ 。右圖：法拉第效應光學隔離器：空氣路徑隔離器（上）和雷射二極體到光纖隔離器（下）。

# 工程發明的精神

- Engineering is the **discipline, art, skill** and profession of acquiring and **applying** scientific, mathematical, economic, social, and practical **knowledge**, in order to **design and build** structures, machines, devices, systems, materials and processes that **safely realize improvements to the lives of people.** -Wiki- English

• **工程學或工學**即「應用科學和技術的原理，來解決問題」。 工程師通過想像，判斷和推理，將科學、技術、數學和實踐經驗應用到設計、製造、對象或程序的操作中。在學校中，將自然科學原理應用至工業、農業各個生產部門所形成的諸多工程學科也稱為**工科或工學**。

-Wiki- 中文版

# 工程發明與五明

**五明**（梵文 pañcavidyā）源於古印度婆羅門傳統，後被佛教接受，指五門學科。《瑜伽師地論》卷38說：五明是「一切菩薩正所應求」。

經云：「菩薩學處，當在五明學處。」；亦即成為一位菩薩，必須通曉五門基本的學識。何謂五明？即聲明、工巧明、醫方明、因明、內明。茲簡述如下：

聲明：語言學、訓詁學等。

工巧明：家務、藝術、科學、農業等。

醫方明：醫學、藥學乃至禁咒等，可以醫治別人色身病苦，拯救眾生。

因明：邏輯學，可以藉此辯證真理。

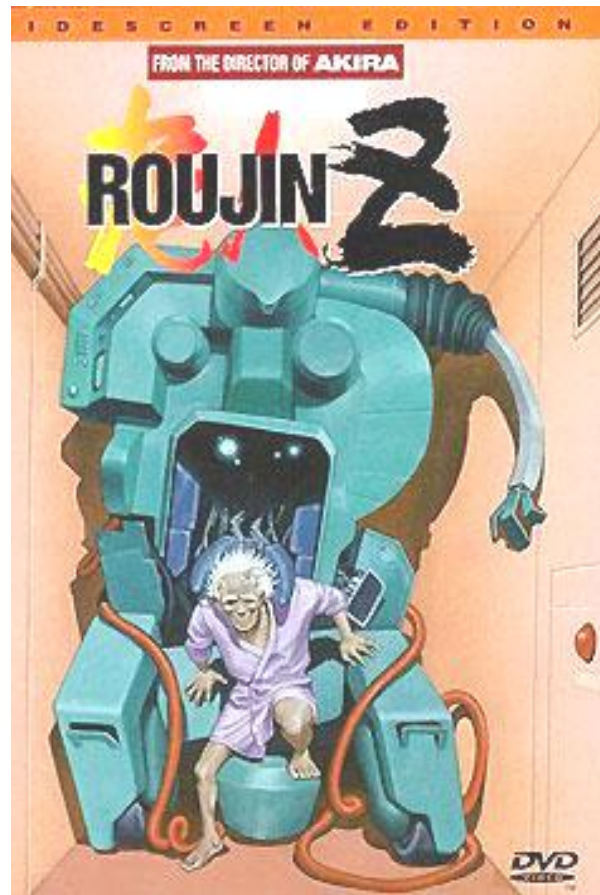
內明：佛法之修學，即對佛理的理解，可以幫助自己修行，亦有利開悟他人。

精通五明的學者，可以享有班智達的稱號。

-Wiki-

# Green + Orange

## Technologies in the Future



大友克洋 1991作品

- Let's open our mind to make this world better ~!

善用人生使用權。

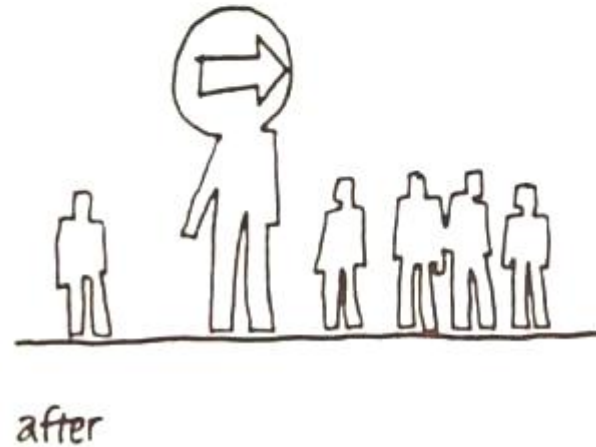
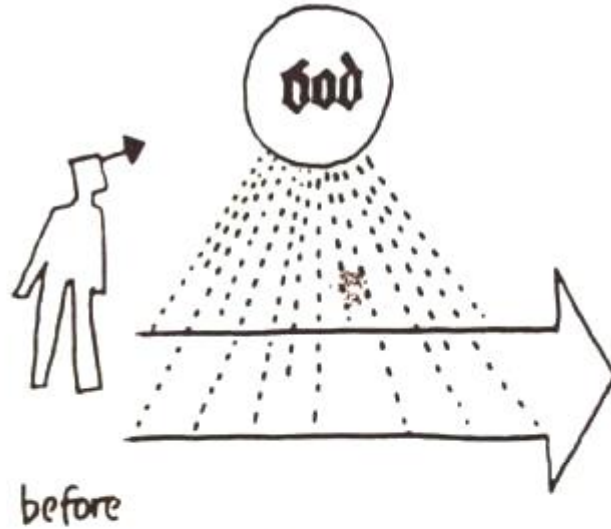


1844-1900  
**Nietzsche**

Supermen  
theory

Nietzsche  
restore man's  
moral fibre.

God was dead.

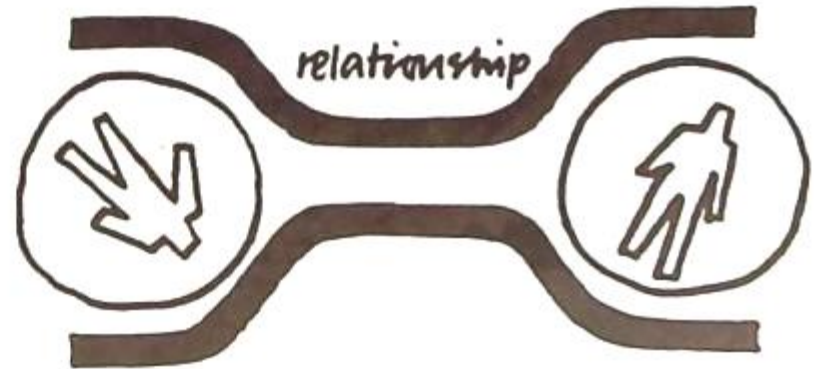
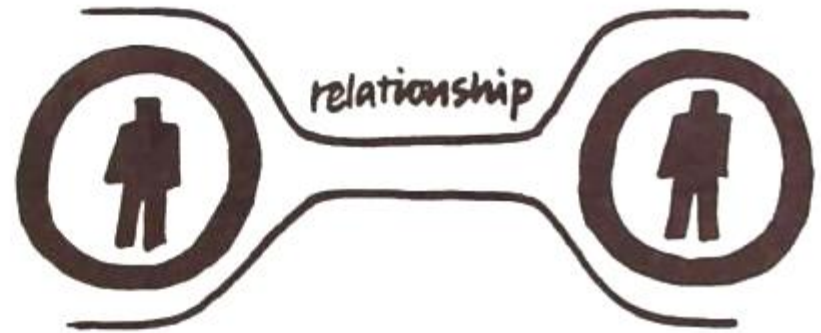


尼采

# 孔子



## Confucius

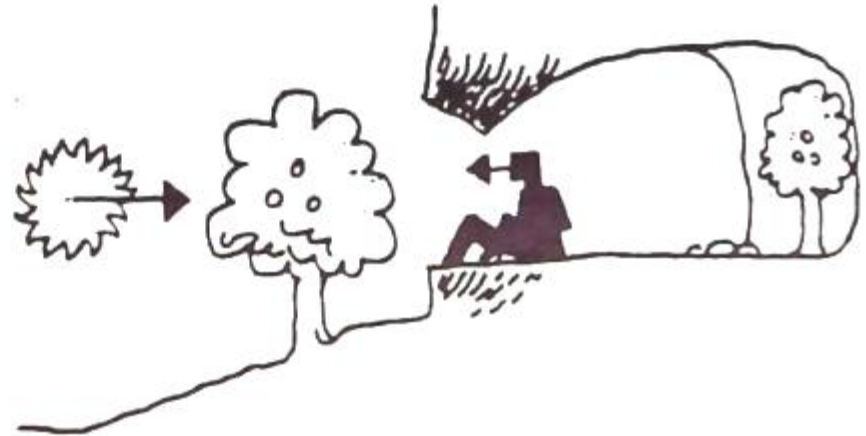
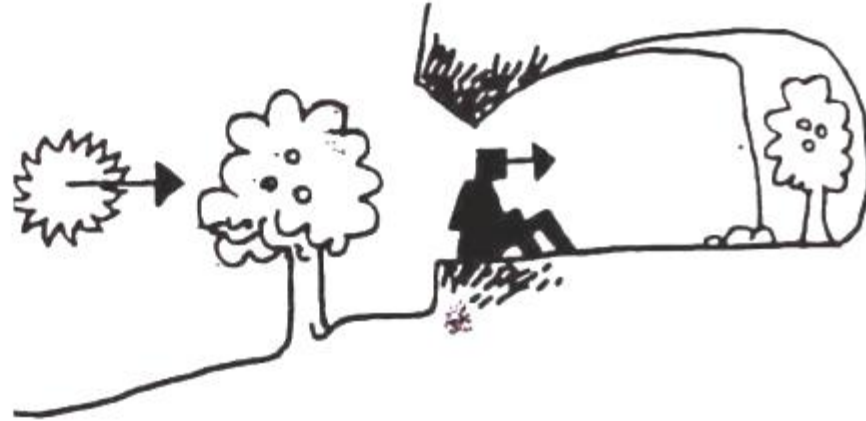


Confucius put all the emphasis on the relation itself. The Christian put more weight on encourage a man or woman to be right within himself/herself)



**Plato**

# 柏拉圖

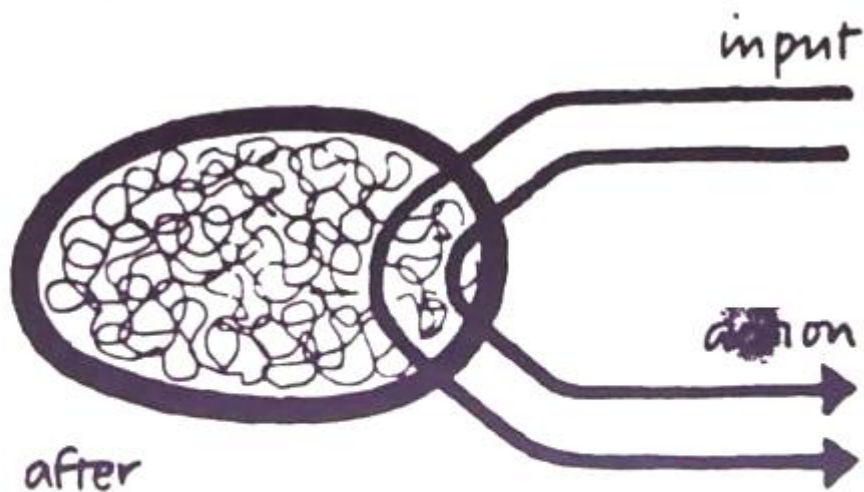
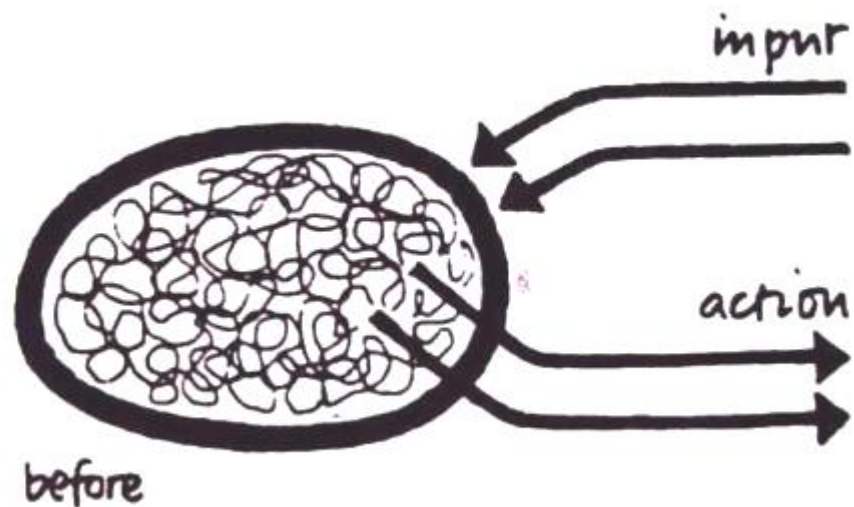


The ordinary man sits in his limited cave and sees only the shadow of reality. Plato insisted that the truth existed as true forms below the surface appearance of things. (Philosopher like to see the truth itself.)

# 帕伐洛夫



Human's behavior could be controlled and predicted.

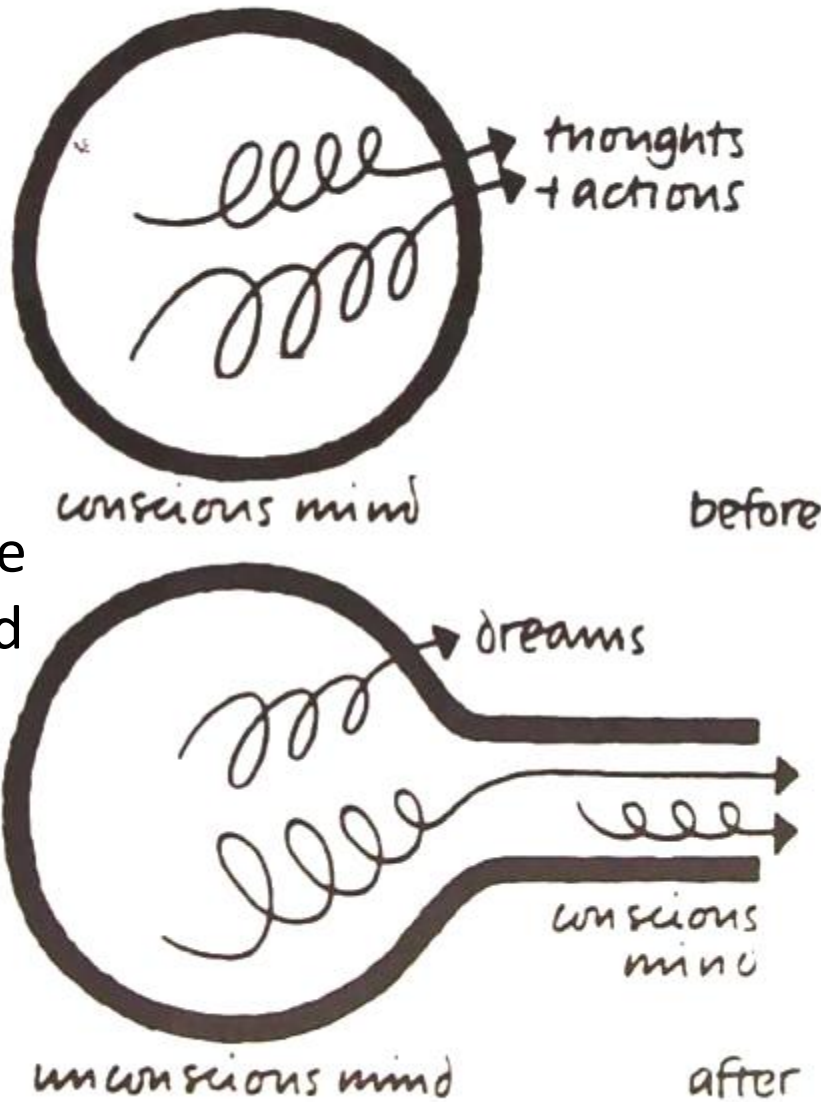




# Freud

The conflicts of the subconscious mind could be seen to explain much of human behavior.

# 佛洛伊德



Sleep Learning

自我暗示有著驚人的力量

睡眠週期九十分鐘

睡眠學習  
睡前暗示

觀察

資源

人際

認知

意欲

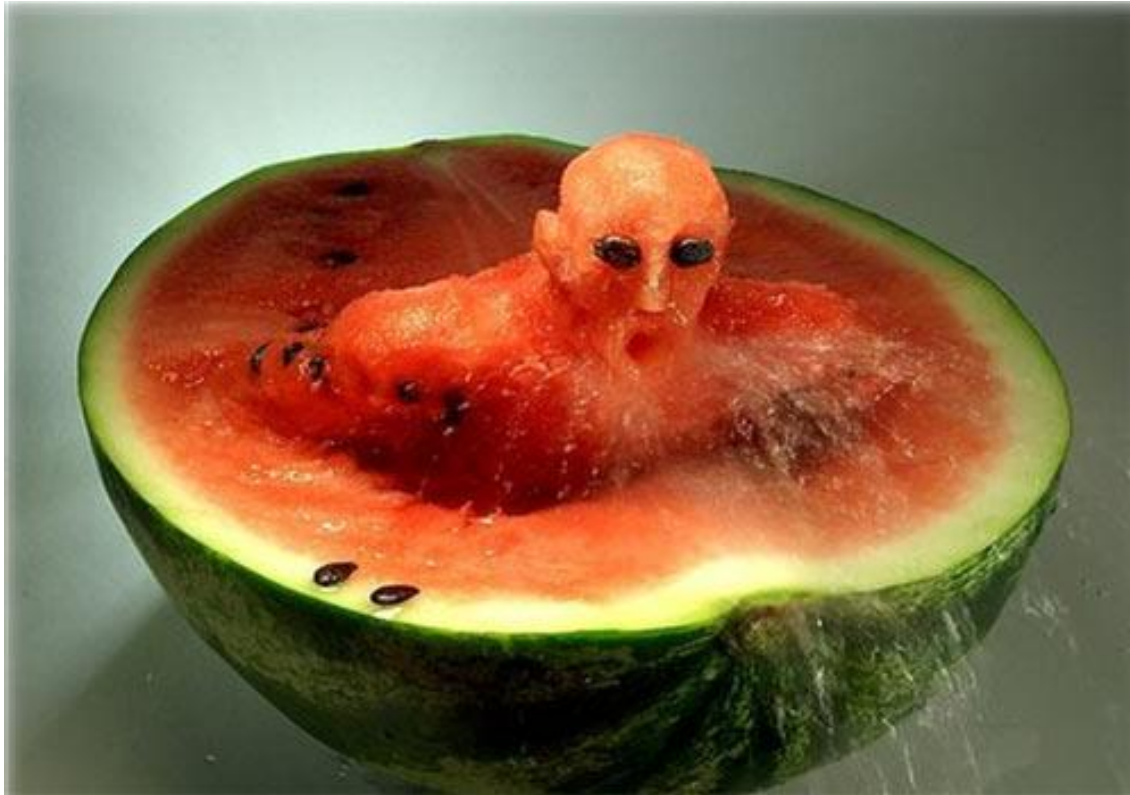
方法

## REFERENCES

1. Weidenfeld and Nicolson, “The Greatest thinkers”
2. Beitz W. and Pahl G., Engineering Design: A Systematic Approach, The Design Council  
London
3. <http://en.wikipedia.org/wiki/>

- 創造思考 — 腦力激盪
  - 創造思考 — 特性聯想
  - 創造思考 — 多元關聯
  - 創造思考技巧 — 形態分析
  - 創造思考 - 水平 + 垂直
- 
- IQ, Age, Education is not required to think creatively
  - Brain Storming
  - Combining old things is one way

- 創造思考 — 特性聯想



Lew D'Souza..

- 創造思考 — 多元關聯



Lew D'Souza..

- 創造思考技巧 — 形態分析



Lew D'Souza..





# Funny Japanese Inventions



# Funny Japanese inventions



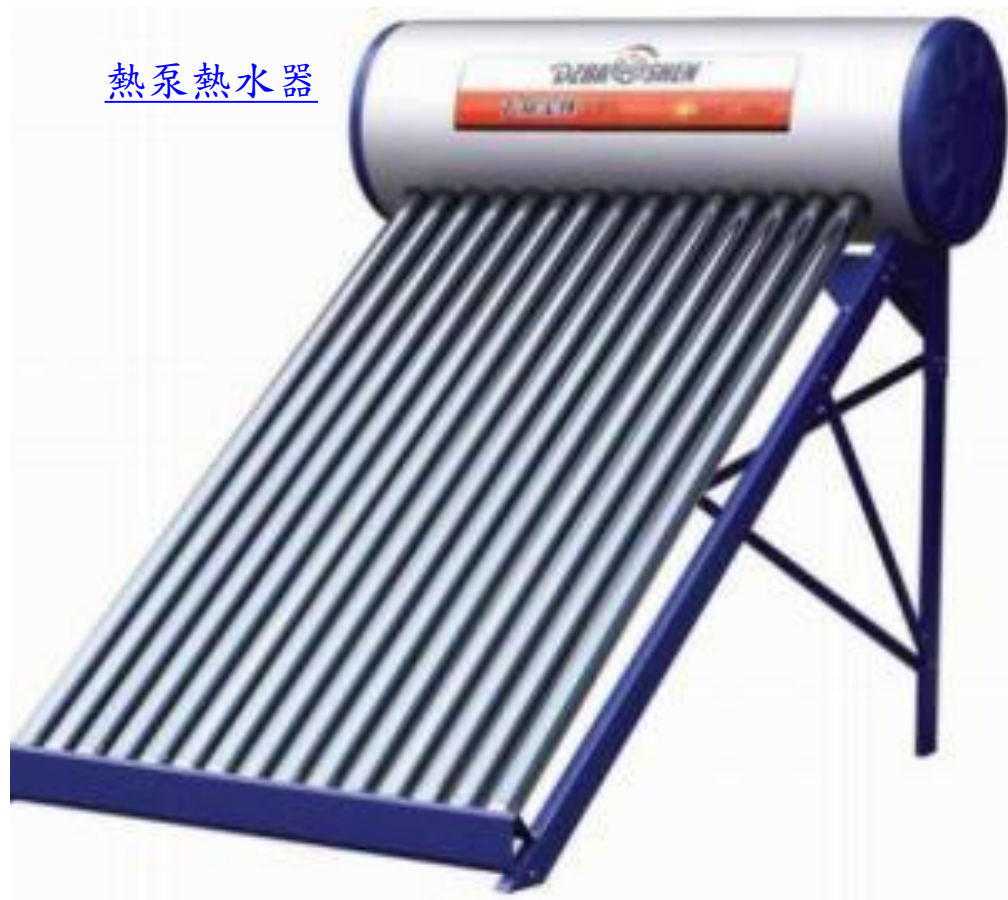
# Funny Japanese inventions



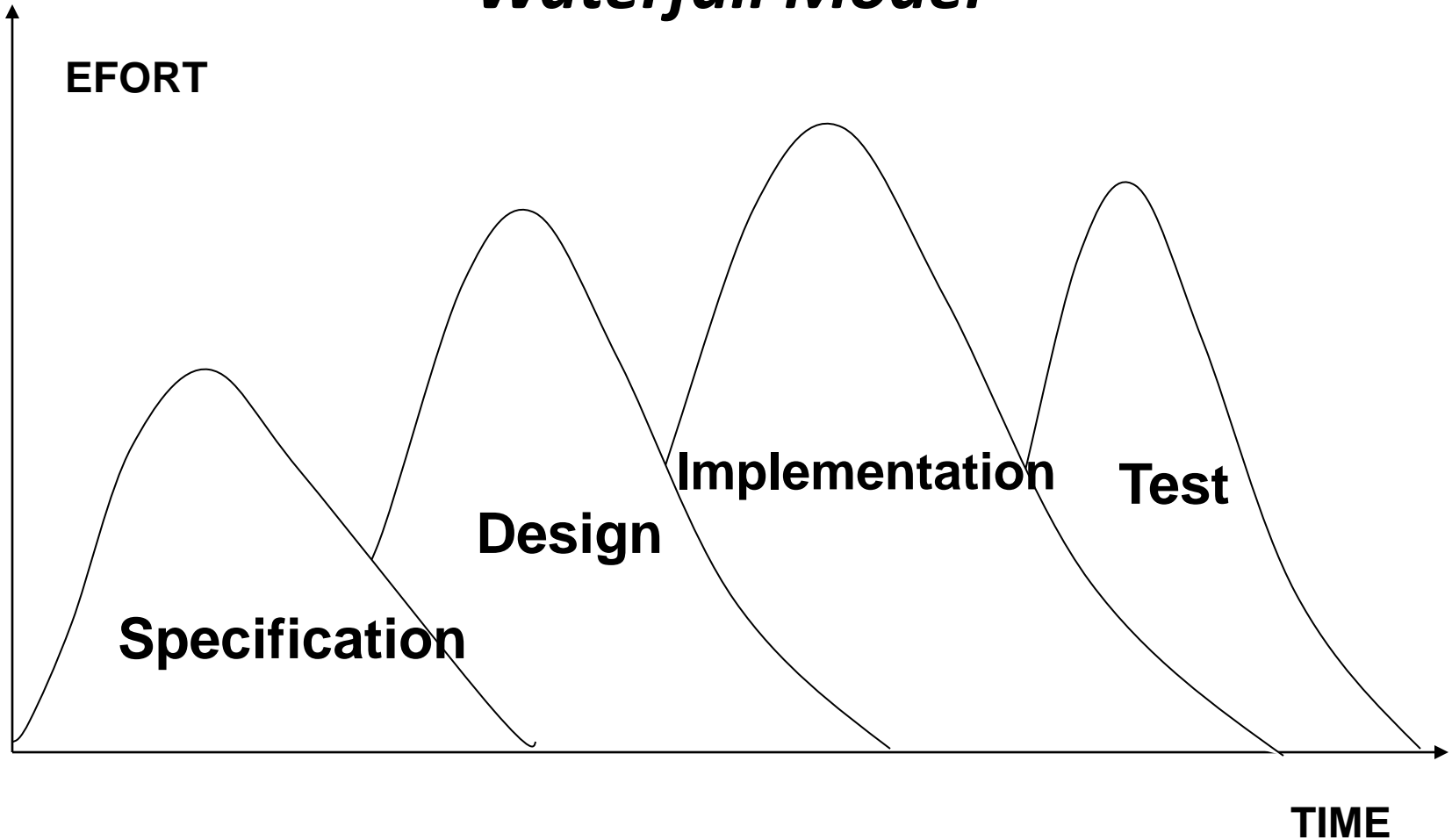




熱泵熱水器

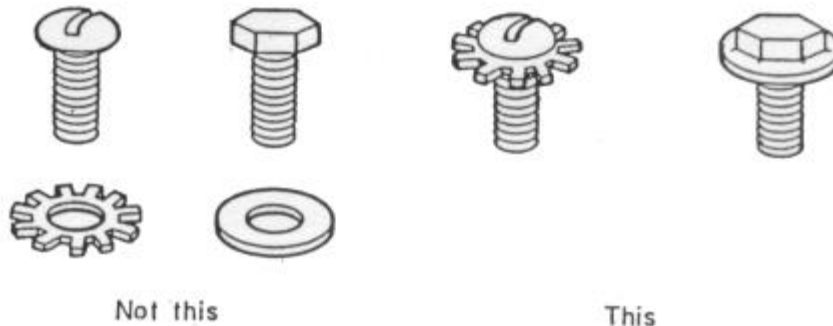


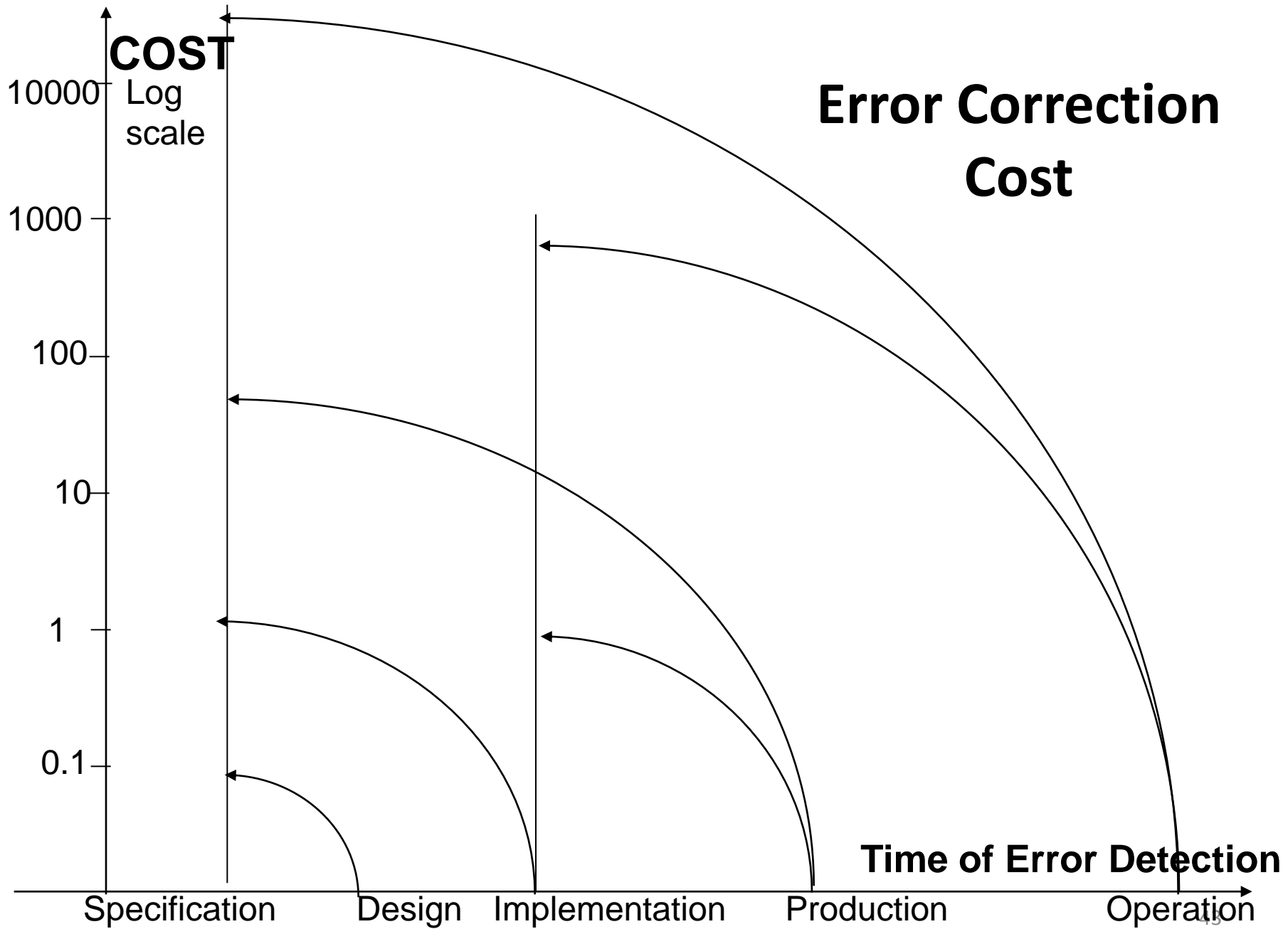
# Design Phase Overlap *Waterfall Model*



# Reduce the Number of Components

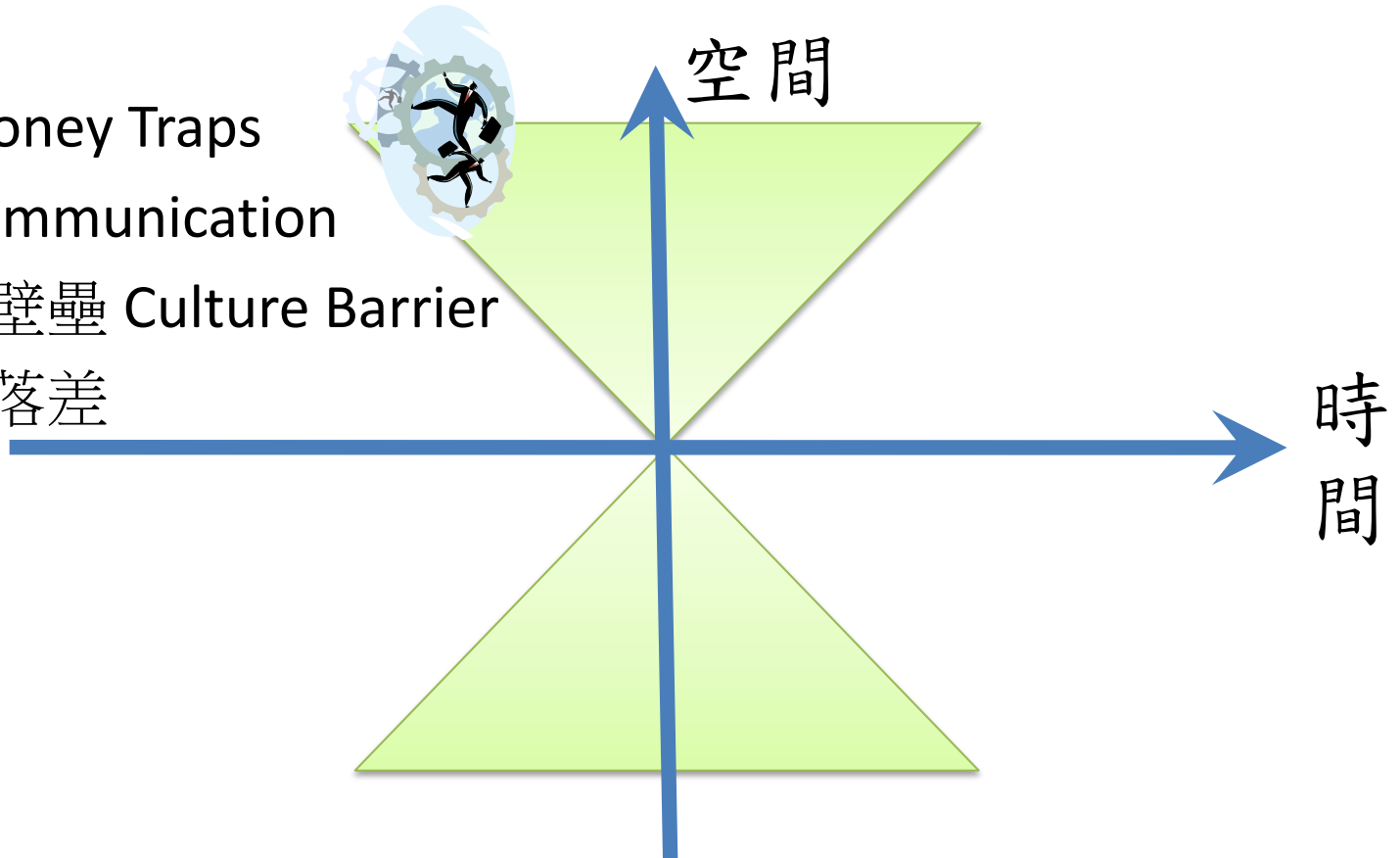
- Benefits from the Reduction
  - Shorter assembly time
  - Lower management cost
- Requirements: retaining original design functionalities.
- Side effects: increase component complexity and manufacturing cost





# 限制?

- 金錢陷阱 Money Traps
- 溝通障礙 Communication
- 文化與生活壁壘 Culture Barrier
- 知識與認知落差
- 物理極限
- 保護主義

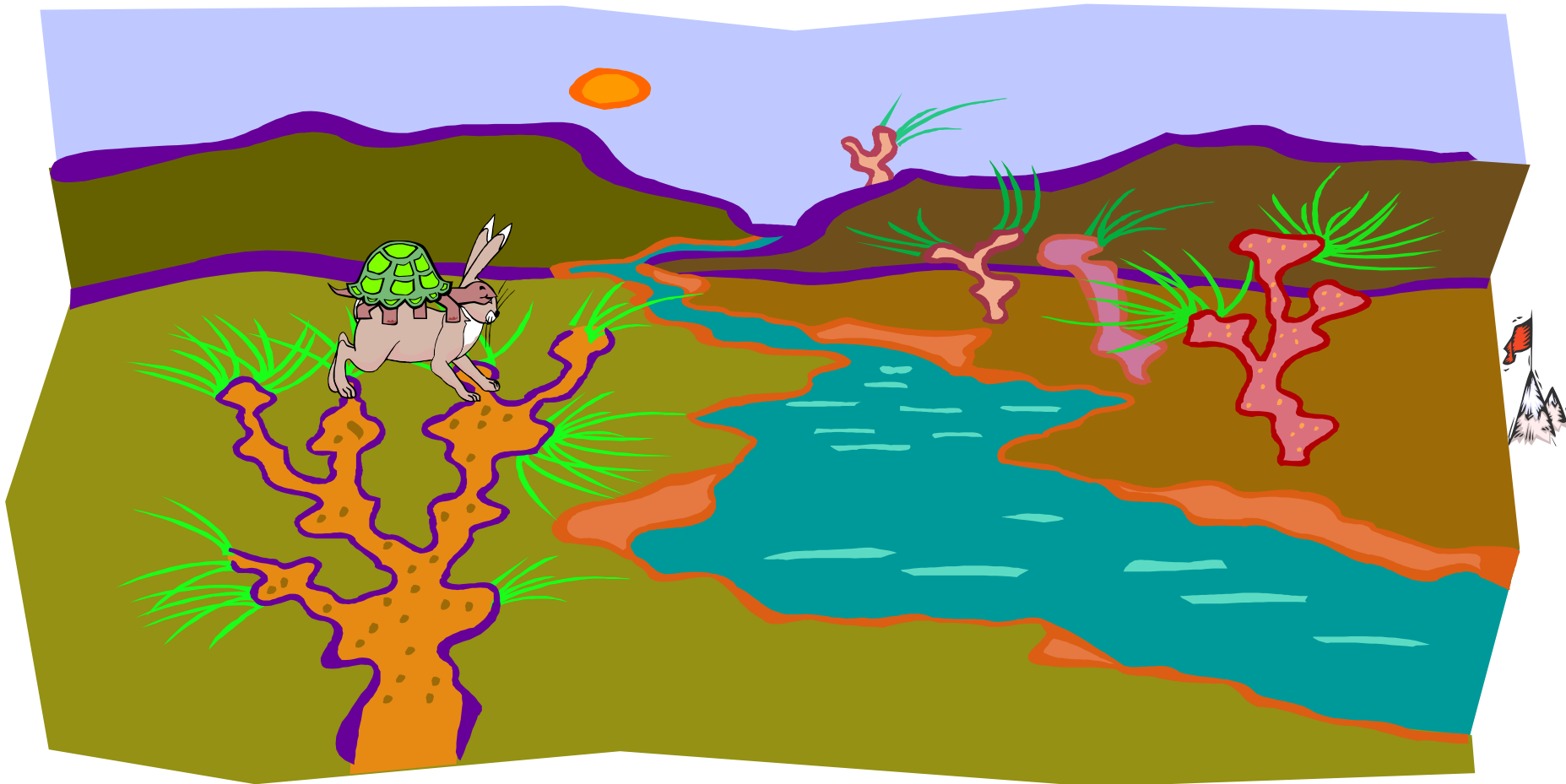


# An Old Story

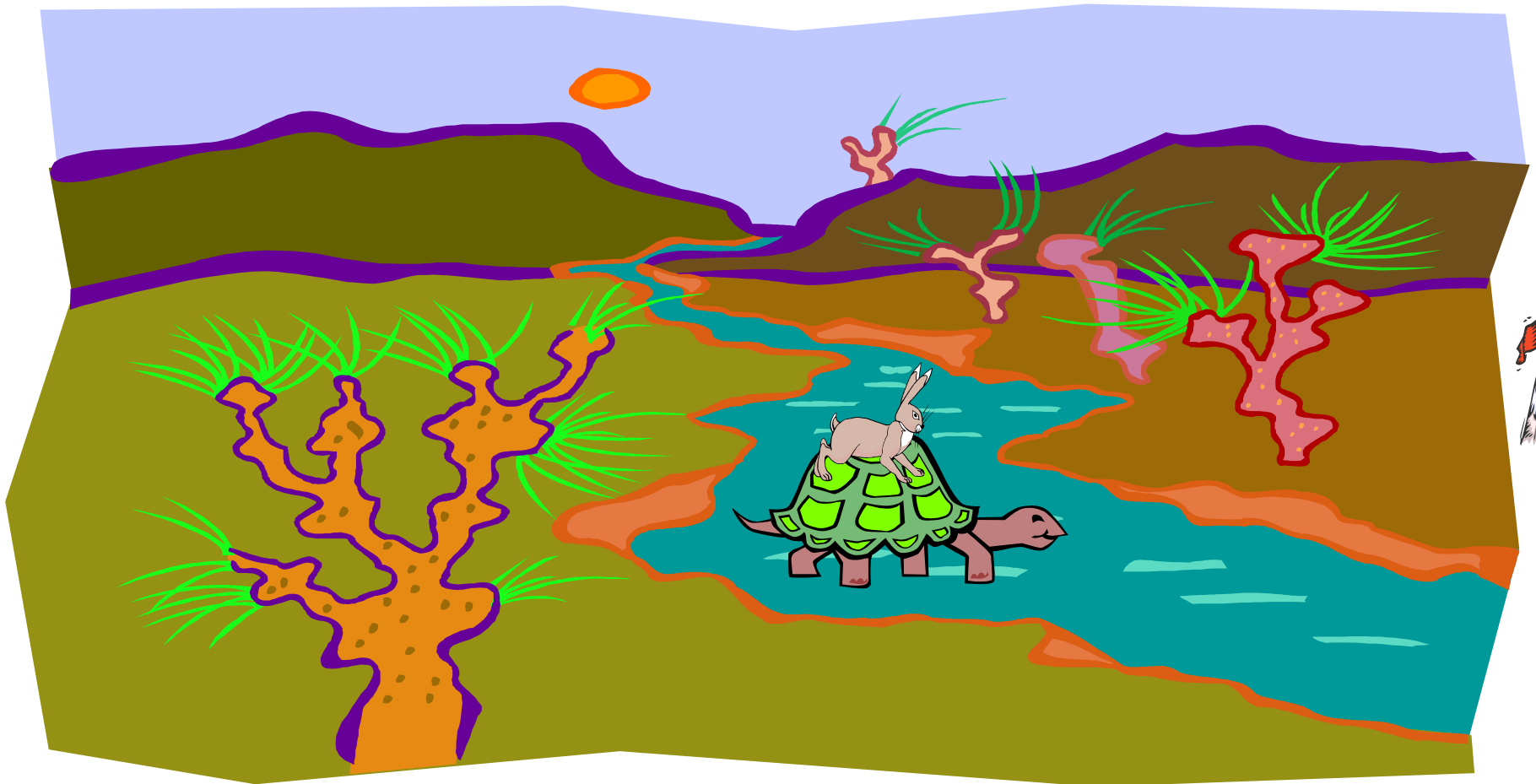
Good old lessons in ***teamwork***  
from an age-old fable



They started off, and this time the hare carried the tortoise till the riverbank.



There, the tortoise took over  
and swam across with the hare  
on his back.



# What is Concurrent Engineering ?



Traditional Process = Linear

Vs

Concurrent Engineering = Team collaboration



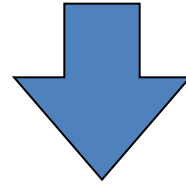
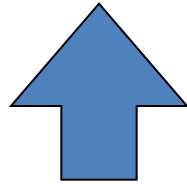
**Concurrent Engineering**



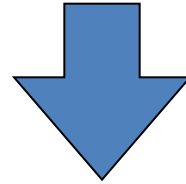
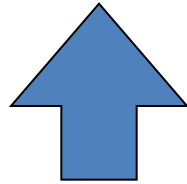
一種哲學  
一種信仰  
一種盼望  
一種藝術  
一種文化



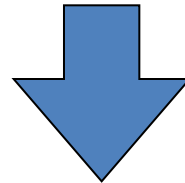
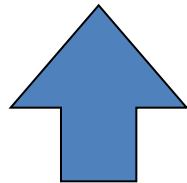
**Creative Thinkers**



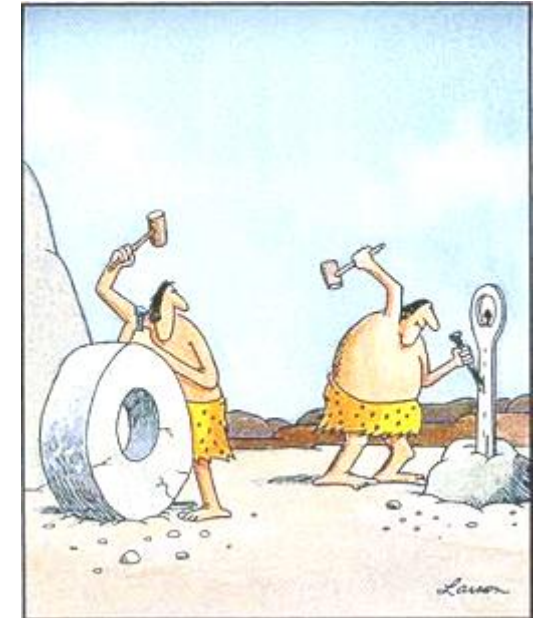
**Design Philosophy**



**Funny Inventions**



**Useful Inventions**



- Practice Problems